

**BOARD OF WATER AND SEWER COMMISSIONERS  
OF THE CITY OF MOBILE**

**MOBILE AREA WATER AND SEWER  
SYSTEM**

**POLICY & PROCEDURE MANUAL**

**2024**

## TABLE OF CONTENTS

### 1.0 SECTION 1 GENERAL

1.1	Description and Organization	1-1
1.2	Definitions	1-1
1.3	MAWSS General Statement	1-2
1.4	Office Address, Office Hours, Information Requests	1-2
1.5	Access to Public Records	1-3
1.6	Procedures for Meetings, Workshops, Public Hearings and Emergency Meetings and Agenda	1-3
1.7	Official Recording	1-3

### 2.0 SECTION 2 PROVISION OF WATER/WASTEWATER SERVICE

2.1	Definitions	2-1
2.2	Classes of Water/Wastewater Service	2-3
2.3	Residential & Commercial Service – No Existing Service Line	2-4
2.4	Residential Service for an Existing Service Line	2-4
2.5	Commercial Service	2-5
2.6	School Service	2-5
2.7	New Service for Multiple Units	2-5
2.8	Irrigation/Pool Meter Service	2-6
2.9	Commercial Water Only Service	2-6
2.10	Right-of-Way Irrigation Service	2-7
2.11	Construction Phase – Temporary Service	2-8
2.12	Construction Phase – Permanent Meter Service	2-8
2.13	Special Event Service	2-9
2.14	Fire Protection Service	2-9
2.15	Grounding of Electrical Systems to Water Lines	2-9
2.16	Reservation of Rights	2-9
2.17	Easements	2-10
2.18	Requirement to Take Both Water and Sewer Services, if Available	2-10
2.19	Grinder Pump Service	2-10
2.20	Wastes Delivered Directly to Wastewater Treatment Facilities	2-11
2.21	Decentralized Systems	2-11
2.22	Backflow Prevention Requirements for Water and Fire Line Services	2-11

### **3.0 SECTION 3 FEES AND CHARGES**

3.1	General	3-1
3.2	Service Fees & Charges	3-1
3.3	Surcharge	3-3
3.4	Meter Test Fee	3-3
3.5	Tampering Charge	3-3
3.6	Service Charge	3-3
3.7	Delinquent Account Charge	3-4
3.8	Return Check Charge	3-4
3.9	Refunds of Overpaid Service	3-4
3.10	Meter Relocation	3-4
3.11	Easement/Right-of-Way/Vacation Charge	3-4
3.12	Development Review and Inspection Fee	3-4
3.13	Locate Sewer Service Connection (Lateral Location)	3-5
3.14	Property Owner Sewer Repair Notices	3-5
3.15	Termination of Sewer Service by MAWSS	3-9
3.16	Basis of Unit Charges – Multiple Units	3-10
3.17	Fire Hydrant Meter Usage	3-11
3.18	Go Back/Turn on Charge	3-11
3.19	Meter Reread Fee	3-11
3.20	Dormant Account Charge	3-11
3.21	Charge to Uncover or Access a Water Meter	3-11
3.22	Third Party Damage to Sanitary Sewer Pressure Services	3-12
3.23	Third Party Sanitary Sewer Overflow Costs	3-12
3.24	Fire Line Abandonment or Repair	3-12
3.25	Sewer Flat Rate	3.13

### **4.0 SECTION 4 BILLING AND PAYMENT FOR SERVICE**

4.1	Billing Period; Due Date; Evidence of Consumption	4-1
4.2	Use of Master Meters	4-1
4.3	Description of Monthly Billing Charges; Minimum Stand-By Charge	4-1
4.4	Basic Water Rate	4-2
4.5	Basic Sewer Rate	4-2
4.6	Untreated Industrial Water Rate	4-2
4.7	Fire Service – Stand-by Charge	4-2
4.8	Installation of Irrigation Meters in Public Common Areas	4-3
4.9	Customer Deposits	4-3
4.10	Delinquent Accounts	4-4
4.11	Billing Disputes; Mistakes	4-4
4.12	Abatement of Water and Sewer Bills	4-5
4.13	Tampering with Facilities	4-5
4.14	Credits Issued to Customers Billed for, but not Connected to the Sewer	4-7
4.15	Wholesale Water Service	4-7
4.16	Wholesale Sanitary Sewer Service	4-7

**5.0 SECTION 5 PRETREATMENT PROGRAM  
RULES AND REGULATIONS**

	<b>PART I GENERAL PROVISIONS</b>	5-1
5.1	Purpose and Policy	5-1
5.2	Objectives	5-1
5.3	Definitions	5-2
5.4	Abbreviations	5-5
	<b>PART II REGULATIONS</b>	5-6
5.5.1	General Discharge Prohibitions	5-6
5.5.2	Federal Categorical Pretreatment Standards	5-8
5.5.3	Modification of Federal Categorical Pretreatment Standards	5-8
5.5.4	Pretreatment Facilities	5-9
5.5.5	Specific Pollutant Limitations	5-9
5.5.6	State Requirements	5-10
5.5.7	Board's Right of Revision	5-11
5.5.8	Excessive Discharge	5-11
5.5.9	Accidental Discharges	5-11
	<b>PART III FEES</b>	5-12
5.6	Purpose	5-12
5.6.1	Charges and Fees	5-12
	<b>PART IV PRETREATMENT PROCEDURES (PERMITTING, COMPLIANCE TRACKING, AND ENFORCEMENT)</b>	5-12
5.7	Identification and Categorization of Discharges and Determination of Pretreatment Requirements	5-12 5-15
5.8	Appeal Procedures for any Pretreatment Requirement	5-15
5.9	Modification of Program Requirements for Dischargers	5-16
5.10	Permits and Contracts	5-17
5.11	Compliance Tracking	5-19
	<b>PART V ENFORCEMENT ACTIONS</b>	5-21
5.12	Actions Available for Enforcement	5-21
5.13	Harmful Contributions	5-21
5.14	Special Charges and Contracts	5-22
5.15	Termination of Contract	5-23
5.16	Termination of Service	5-23
5.17	Legal Action	5-24
	<b>PART VI INDEMNIFICATION</b>	5-24
	<b>PART VII SEVERABILITY</b>	5-24
	<b>PART VIII CONFLICT</b>	5-24
	<b>PART IX EFFECTIVE DATE</b>	5-24
	<b>PART X SPECIAL AGREEMENTS</b>	5-25

<b>6.0</b>	<b>SECTION 6 CROSS-CONNECTION CONTROL</b>	6-1
6.1	Intent of Policy	6-1
6.2	Definitions	6-1
6.3	Statement of Policy	6-4
6.4	New Service Connections	6-5
6.5	Existing Service Connections	6-6
6.6	Responsibilities of MAWSS, Customers, & Testers	6-6
6.7	Additional Rules for Protection of MAWSS' Water Supply System	6-7
6.8	Description and Causes of Backflow	6-8
6.9	Approved Backflow Prevention Methods	6-8
6.10	Backflow Prevention Selection Criteria	6-12
6.11	Facilities Requiring Backflow Prevention Assemblies	6-14
6.12	Approved Backflow Prevention Assemblies	6-15
6.13	Installation of Assemblies and Standard Details	6-15
6.14	Backflow Prevention Assembly Removal	6-18
6.15	Testing & Repairs of Backflow Prevention Assemblies	6-19
6.16	Inspection of Backflow Prevention Assemblies	6-21
6.17	Reports and Records	6-22
6.18	Non-Compliance with Policy	6-22
6.19	References	6-22
	<b>Appendices</b>	
	Appendix A – Forms	6-23
	Appendix B – Customer Checklists	6-24
	Appendix C – Standard Details	6-25
	Appendix D – Thermal Expansion Protection	6-26
	Appendix E – Facilities Requiring Backflow Prevention	6-27
	Appendix F – Approved Backflow Preventers	6-28
	<b>Tables</b>	
	Table 1. Potential Backflow Hazards	6-13
	Table 2. Means of Backflow Prevention	6-13
	Table 3. Summary of Backflow Prevention Assembly Installation and Testing	6-20
	<b>Figures</b>	
	Figure 1. Double Check Valve Assembly (Section)	6-9
	Figure 2. Double Check Valve with Detector Assembly (Section)	6-10
	Figure 3. Residential Dual Check Valve (Section)	6-111
	Figure 4. Reduced-pressure Principle Backflow Prevention Assembly (Section)	6-11
	Figure 5. Reduced-pressure Principle Detector Backflow Prevention Assembly (Photo)	6-12
<b>7.0</b>	<b>SECTION 7 WATER/WASTEWATER MAIN EXTENSIONS &amp; METER CONVERSIONS</b>	
7.1	General	7-1
7.2	Definitions	7-1
7.3	Water/Wastewater Main Extensions, When Required	7-2
7.4	Water/Wastewater Main Extension Procedure – New Developments	7-4
7.5	Main Extension Process – Existing Communities	7-7
7.6	Service to Subdivisions	7-9

7.7	Contribution for New Developments	7-9
7.8	Fire Protection	7-9
7.9	Service Line Component of the Connection Fee; Reimbursement; Collection; Enhanced Main Extension Rebate	7-10
7.10	Acceptance of Main Extensions	7-11
7.11	Apartment Complex Meter Conversion	7-13
7.12	System Design; General Criteria	7-15
<b>APPENDICES</b>		
	Appendix A – No Content	7-16
	Appendix B – No Content	7-17
	Appendix C – Connection Fee Examples (please see Fee Schedule for current rates)	7-18

SEE NEXT PAGE

## FEE SCHEDULE

<b>I. MONTHLY FEES AND CHARGES</b>		
A.	Basic Water & Sewer Rate/1000 Gals	Fee-1
B.	Minimum Charge/Meter Size & Consumption (1,000 Gal)	Fee-1
C.	Fire Service – Stand-By Charge	Fee-1
D.	Untreated Industrial Water Rate	Fee-1
E.	Decentralized Systems	Fee-1
F.	Wholesale Water	Fee-1
G.	Wholesale Sanitary Sewer	Fee-1
H.	Sewer Flat Rate	Fee-1
<b>II. SERVICE FEES &amp; CHARGES</b>		
A.	Capacity Fee	Fee-2
B.	Service Line Installation (Tap) Fee	Fee-2
C.	Service Line Connection Fee (includes meter)	Fee-2
<b>III.</b>	<b>CUSTOMER DEPOSITS</b>	Fee-2
<b>IV.</b>	<b>ADDITIONAL FEE CHARGES (must be prepaid)</b>	Fee-3
<b>V.</b>	<b>WET TAPS (TAPPING VALVES &amp; SLEEVE)</b>	Fee-3
<b>VI.</b>	<b>TAPPING FEE CHARGES – ADDITIONAL SERVICES</b>	Fee-4
<b>VII.</b>	<b>INDUSTRIAL PRETREATMENT PROGRAM FEES &amp; CHARGES</b>	Fee-4
<b>VIII.</b>	<b>MISCELLANEOUS FEES &amp; CHARGES</b>	Fee-5

## SECTION I

### GENERAL

#### 1.1 Description and Organization

The Board of Water and Sewer Commissioners of the City of Mobile is a public agency existing under the provisions of Act No. 775, adopted at the 1951 Regular Session of the Legislature of Alabama, amended and rectified as Code of Alabama 1975, Sections 11-50-340 through 11-50-358 and by ordinance adopted by the governing body of the City on September 18, 1952.

#### 1.2 Definitions

The terms set forth below shall have the following meaning:

**Act** – shall mean Act No. 775, Code of Alabama 1975, Sections 11-50-340 through 11-50-358, as amended.

**Board – shall** mean the Board of Water and Sewer Commissioners of the City of Mobile, doing business as the Mobile Area Water and Sewer System (MAWSS).

**Director** – shall mean the Director of the Mobile Area Water and Sewer System.

**Emergency Meetings** – shall mean meetings held for the purpose of expediting action upon emergency matters affecting the public health, safety or welfare.

**MAWSS** – shall mean the Mobile Area Water and Sewer System.

**Public Hearing** – shall mean a public gathering of the Board for the sole purpose of obtaining information and receiving public comment on activities proposed by the Board, but at which no official action shall be taken nor policy adopted.

**Public Meeting** – shall mean a meeting of the Board for the purpose of conducting public business.

**Secretary-Treasurer** – shall mean the person elected by the Board to act in that capacity.

**Workshop** – shall mean a gathering of members of the Board and/or its staff as designated by the Board for the purpose of discussion of MAWSS business and projects, at which time rule drafting may occur but no official vote may be taken or policy adopted. Such workshops shall be open to the public, but it shall be within the sole discretion of the presiding officer whether or not to permit public comment, and no official records of the matters discussed at the workshop shall be required to be maintained or recorded.



### **1.3 MAWSS General Statement**

Mobile Area Water and Sewer System will protect and enhance the health, safety, and economic well-being of our community through responsible management of water resources while providing superior customer service.

The service area of the Board includes the incorporated limits of the City of Mobile and areas outside of the limits of the City or County of Mobile where the Board provides services or determines to provide service.

The Board shall exercise all powers enumerated in the Act, including but not limited to, jurisdiction, control, and supervision over any water system or sewer system operated or maintained by the Board and shall also exercise such other authority as may exist under general or specific law. The Board has the power to fix, revise, charge, and collect rates, fees, and charges for the use or for the services and facilities furnished by any system operated by the Board, and to fix higher, lower, or additional charges which it deems necessary under the circumstances peculiar to the services rendered to any customer. In addition, the Board may contract with municipalities or others at lower or higher rates than those charged to its customers.

The Board may request grants from EPA (Environmental Protection Agency) or any other federal or state agency or any other available source and will ensure compliance with any regulations or requirements that must be met.

The Board governs the policy making and other prescribed duties and powers pursuant to the Act. The Board shall consist of seven members, pursuant to the Act, as amended.

The Board shall elect one of its members as Chairman and one of its members as Vice Chairman, and one of its members as Secretary Treasurer. A majority of the members of the Board shall constitute a quorum. No vacancy in the Board shall impair the right of a quorum to exercise all of the powers and duties of the Board. All members of the Board shall be required to be bonded and any vacancy appearing on the Board shall be filled by an appointment made by the City Council.

A Director shall be appointed by the Board to manage MAWSS on a day-to-day basis. An administrative staff shall perform the various functions required for the day-to-day operation of MAWSS under the management of the Director. The Board may retain outside consultants or legal counsel, as it deems necessary for the performance of its duties.

### **1.4 Office Address, Office Hours, Information Requests**

The principal offices of MAWSS are located at 4725 Moffett Rd Ste A, Mobile AL 36618, MAWSS Park Forest Plaza. There is a satellite office at 1060 Springhill Ave. The mailing address is PO BOX 180249, MOBILE AL 36618-0249. The telephone number is (251) 694-3100. The Board's website is [www.mawss.com](http://www.mawss.com).

Office hours are from 8:00 A.M. to 4:30 P.M. daily, Monday through Friday, except on Board approved holidays. Call Center hours are 7:00 A.M. to 5:00 P.M. daily. To report emergencies, you may call (251) 694-3165 – 24 hours, 7 days a week.

Unless otherwise specifically provided in these rules, all comments, correspondence, communications, or requests for information should be made in writing and addressed to the Board or the Director at the principal office in Mobile, Alabama. Requests for placement on any notice or mailing list should be made in writing and addressed to the Secretary-Treasurer at the principal office.

### **1.5 Access to Public Records**

Forms and instructions used by MAWSS in conducting its business are available without cost at the principal office. Copies of other public records may be made at a charge. This Policy and Procedure Manual is available on the MAWSS website at [www.mawss.com](http://www.mawss.com).

If more than twenty pages are requested to be copied, MAWSS may require that the copies be made at its convenience, within a reasonable time, to be picked up by the recipient or forwarded to the recipient at his cost. In that event, the person seeking the public records shall pay the cost of such copies and the estimated postage fee in advance. Requests requiring a record search will be billed based on actual cost of time, plus 50%.

### **1.6 Procedures for Meetings, Workshops, Public Hearings and Emergency Meetings, and Agenda**

All public meetings, workshops, public hearings, and public forums shall be conducted in accordance with the Alabama Sunshine Law.

The Board abides by the Alabama Open Meetings Act and follows the notice requirement. Notice of all public meetings, workshops, and hearings shall be posted in MAWSS' Office Lobby and on MAWSS' website at [www.mawss.com](http://www.mawss.com). Such notice shall state time, date, location, and purpose of the meeting.

The Board may hold an emergency meeting for the purpose of acting upon emergency matters affecting the public health, safety, or welfare. The Board will reasonably attempt to notify the public at least 24 hours prior to the meeting of the time, date, place, and purpose of the meeting.

An agenda shall be prepared by MAWSS in time to ensure that a copy may be received at least one day before the meeting by any person who has requested a copy. The agenda may also be viewed on MAWSS' website.

### **1.7 Official Recording**

Minutes of the Board meetings may be found on the MAWSS' website at [www.mawss.com](http://www.mawss.com).

## SECTION 2

### PROVISION OF WATER/WASTEWATER SERVICE

#### 2.1 Definitions

When used in these rules:

**Active Account** means that a Contract for Service exists between a customer and MAWSS, under which service is rendered and payment for said service is made on a monthly basis.

**Business Day** means the period of each day from 8:00 A.M. to 4:30 P.M., excluding Board approved holidays and weekends.

**Collection Line** means the pipes owned by MAWSS and used to collect wastewater from laterals and deliver to wastewater treatment facilities.

**Customer** means an individual, corporation, partnership, firm, or association receiving water or wastewater service from MAWSS for consumption or usage within its premises.

**Day** means one twenty-four hour period, midnight to midnight.

**Developer** means an individual, private or public corporation, partnership, firm or association or other entity, including governmental agencies and other units of government developing property for resale, rental or lease, to which water and/or wastewater service will be rendered by MAWSS.

**Deduct Meter** is a service used to provide water that flows through an existing domestic line that can be monitored and billed water only. This service is designed to eliminate the sewer charge for production water that does not enter the system.

**Distribution Line** means the pipes owned by MAWSS and used for the distribution of water to the service lines.

**Inactive Account** means an account for which service by MAWSS had been previously rendered but for which no current Contract for Service is held by MAWSS.

**Month** means the time interval between successive meter reading dates, which is approximately thirty days.

**Owner** means a person, firm, private or public corporation, association or other entity, including governmental agencies and other units of government, having any interest whatsoever, whether legal or equitable, sole or partial, in any premises, but does not include a customer renting the premises.

**Point of Delivery** means the point where MAWSS' meter or lateral is connected to customer owned or operated facilities and where service to the customer begins. It is also the location at which the responsibility of maintaining the water or sewer facilities passes from MAWSS to the customer. In the water system, the point of delivery is generally at the location of the water meter. MAWSS will maintain the meter and the service line, not the plumbing from the meter to the

customer's facilities. If no meter is required, the point of delivery is the point where MAWSS' pipe is connected to customer owned or operated facilities.

*NOTE: In the sanitary sewer system, the point of delivery is generally at the back side of the curb in the City of Mobile where the street curb, sidewalk, and buildings are adjacent, and at the property line in other areas of the City and in Mobile County. For sewer mains that are located in easements on private property (not in a Right-of-Way), the customer is responsible for maintaining the sewer service line from the building to the sewer main, including the service line connection at the main. In any case mentioned above, the customer is responsible for clearing any blockages that may occur in the sewer service line from the building to the sewer main. Damages resulting from backup in service due to blockages are the responsibility of the customer. Check with your homeowner's insurance company to purchase specific sewage coverage insurance for a nominal fee. Customer is responsible for adhering to the City Plumbing Code by installing proper cleanouts and backflow preventers on their lines.*

In cases where the aforementioned does not clearly apply, MAWSS shall designate the point of delivery and the designation shall be final.

**Potable Water**, also known as drinking water, is water that has been treated to meet stringent regulatory requirements and is safe for human consumption.

**Premises** means any and all real property or tangible personal property affixed to real property served by MAWSS, or capable of being served by MAWSS as a result of the existence of a service connection.

**Raw Water** – water that is initially drawn from Big Creek Lake or the Mobile River and conveyed to industrial customers for fire suppression or industrial processes. This water receives no treatment whatsoever. It is provided to the customer in as-is condition from the aforementioned sources or other reservoirs in which it may be stored. It is not potable.

**School** means any public school in Mobile County, Alabama, accredited by the State of Alabama. **Unless otherwise designated by the Board.**

**Service** means the supply of water or wastewater to the point of delivery by MAWSS. It includes the readiness and ability on the part of MAWSS to furnish water and sewer service to the customer on demand due to the presence of a service connection.

**Service Line** means the pipe maintained and operated by MAWSS which connects the distribution line to the point of delivery.

**Sewer Lateral** means a sewer line that branches off of a sewer main.

**Standard Specifications for Water Mains, Sanitary Sewers and Sewage Pumping Stations** (Standard Specifications) – a separate manual that provides a basis for system improvements to the MAWSS system. A copy may be obtained from MAWSS' website at [www.mawss.com](http://www.mawss.com).

**Subtraction Meter** is service whereby one line serves multiple customers through one master meter with each subsequent customer having a separate meter. Consumption from all subsequent meters is billed individually and the total is subtracted from the master meter.

**Tampering** means any willful alteration, vandalism, or interference with the fire hydrant, water meter, meter seal, locks, or other system components belonging to MAWSS, except for turning on or off the valve associated with the water meter for the purpose of temporary disconnection of service. Tampering should include turning on said valve for the purpose of obtaining water service to premises not subject to a Contract for Service with the present occupants as well as illegal usage via straight-line or other means.

**Unit** means each apartment and separate use of a part of any dwelling, whether or not under the same roof or within the same building; each part of any shopping center used by separate tenants whether under one or more roofs; and each separate outlet to each trailer court.

## **2.2 Classes of Water/Wastewater Service**

**Residential Service** is service to one or more single-family dwelling unit(s) served by a 5/8 inch meter or one single-family dwelling unit served by a one inch or larger meter that receives basic water and/or sewer service. For residential service with greater than a 5/8 inch meter serving more than one unit, see Multiple Unit Service.

**Commercial Service** is service to any premises used for commercial purposes, consisting of at least one business entity and served by a 5/8 inch meter or larger connection.

**Construction Phase – Permanent Meter Service** means service provided at the job site at the correct size meter but billed at a 5/8" meter rate. This service is to facilitate construction and provide water for testing the plumbing only. The meter is adjacent to the MAWSS system.

**Construction Phase – Temporary Meter Service** is service for a pre-established time period, through a water meter on service lines that are pending acceptance by the Board. The meter is always located within the development and is a part of the construction. This meter does not provide water for ingestion.

**Wholesale Service** means service to other water utilities at a wholesale rate for their resale and distribution.

**School Service** is service to – **any school per previous definition.**

**Multiple Unit Service** is service to customers with more than a single unit through a one-inch meter or greater.

**Industrial Raw Water Service** is service to a customer receiving raw water for industrial processing. Raw water is provided as-is to the customer with no minimum standard of quality. The suitability of raw water for any particular purpose is not guaranteed. The customer is responsible for analyzing the water and determining its suitability for the customer's purpose. Raw water quality will vary from time to time. Customers must provide their own means of safeguarding their equipment from such variations in water quality. Customer's using raw water are encouraged to install turbidity meters at the points of service so that alarming can occur if turbidity exceeds customer's defined limits. Industrial Raw Water Service is metered and billed according to consumption.

**Irrigation/Pool Meter Service** is service exclusively used for the purposes of landscape, yard irrigation, or filling swimming pools, providing that none of the water returns to the sanitary sewer system.

**Commercial Water Only** is a non-domestic water service dedicated to a commercial use, as supplying water to an air conditioning cooling tower, ice producing equipment, or other commercial system, where the customer can demonstrate that the dedicated water used only enters the sanitary sewer system through an approved MAWSS wastewater meter. This type of service can be provided through a dedicated water line directly from a metered public water main or through a line branching off of the domestic water line and passing through a deduct water meter. If an approved wastewater meter is installed, the customer will be charged at the then current sewer rate for the volume of wastewater passing through the wastewater meter. If the possibility exists that waste could enter MAWSS' system by means of a floor drain used for emergency purposes, and a wastewater meter is not installed then a minimum sewer charge will be applied to the monthly account in addition to the water charge. The amount of this minimum sewer charge will depend on the size meter installed.

**Right-of-Way Irrigation Service** is service exclusively used for the purposes of landscaping within public rights-of-way, provided that none of the water returns to the sanitary sewer system.

**Special Event Service** is temporary service provided to scheduled special events.

**Fire Protection Service** is service to any fire protection system, including automatic sprinkler systems, hydrants, and standpipes.

### **2.3 Residential and Commercial Service – No Existing Service Line**

Where no existing service line exists for water and/or sewer, the applicant must present legal description of the premises. The owner/builder/contractor will be required to present a copy of the building permit for the structure to be erected on the property and pay all applicable fees and charges. On non-rental residential connections, a Contract for Loan is available to finance the sewer portion of the connection fees.

A lien shall be placed on the property and recorded in the Office of Probate of the county of Mobile. MAWSS will not subrogate its lien position. The loan will be connected to the water bill and bill each month in the water bill until the loan portion is paid in full. Once the contract for loan has been paid in full, MAWSS will release the lien and notify the customer in writing. A contract of loan is not available to non-residential customers, business, or in areas where MAWSS only has sewer services.

### **2.4 Residential Service for an Existing Service Line**

To obtain Residential Service from an existing service line or existing service lateral, application should be made at MAWSS' office. The applicant must present identification (preferably Driver's License or other photo identification), or Social Security card. Legal description of the premises and proof of ownership or occupancy will be required prior to establishment of service at a location with prior delinquent service. The Contract for Service shall be executed by the owner(s) as listed in the recorded deed or legal tenant(s) named in a rental or lease agreement. The applicant should insure that his/her name, the street address or legal description of the premises, and other

required information are correctly entered. Upon payment of all required fees and charges, the Contract for Service will be executed by the parties.

MAWSS assumes no liability if a water or sewer line is not available. Service may be provided at such future time at the discretion of the Board.

It is the property owner's responsibility to verify functionality of the existing sewer service lateral. MAWSS assumes no liability for property damage resulting from using a defective or capped sewer lateral.

## **2.5 Commercial Service**

In the case of new commercial service or when a modification is made to premises such that a commercial operation of any type will be located in a formerly residential facility, the owner will be required to present plans and specifications for MAWSS review prior to the acceptance of any fees, deposits, or the execution of a Contract for Service.

A Contract for Service for a corporation shall be executed by an authorized officer of the corporation. (Confirmation of authorized officer is required and may be provided in the form of: Articles of Incorporation, Minutes, By-Laws, letter of introduction on corporation letterhead and signed by designated officer, etc.) If such person's representative capacity is not indicated on the Contract of Service, such person shall be personally responsible for the account.

A Contract for Service by any commercial entity other than a corporation shall be signed by an individual, or individuals, who shall be personally responsible for the account.

It is the property owner's responsibility to verify functionality of the existing sewer service lateral. MAWSS assumes no liability for property damage resulting from using a defective or capped sewer lateral.

## **2.6 School Service**

Application for School Service shall be made in the same manner as for Residential Service.

## **2.7 New Service for Multiple Units**

Application for service for multiple units regardless of meter size shall be made in the same manner as for single unit Residential Service, with the following additional requirements:

Upon application for water or sewer service, the applicant must file a certified statement showing the number of units within each multiple dwelling, apartment house, duplex apartment, office building, or other multiple unit structure.

The applicant must present to the Mapping and Connections Department all plans and specifications covering the proposed construction, including the Plan Review Fee as contained in the Fee Schedule. A registered professional engineer shall seal plans and specifications presented.

It is the responsibility of the owner to notify MAWSS of any permanent changes to the number of units. No refunds will be made in the event the customer fails to notify MAWSS of a reduction in units.

## **2.8 Irrigation/Pool Meter Service**

Irrigation/Pool Meter Service will be installed only at locations where no water passing through the meter will be discharged into the sanitary sewer.

Application for Irrigation/Pool Meter Service shall be made in the same manner as for Residential Service.

**Backflow Prevention** – See MAWSS Cross Connection Control Policy

**Billing** – The minimum monthly water charge will be billed for those months when the Irrigation/Pool meter is not used.

If a customer wishes to have the meter turned off during the months it is not in use, a service charge will be required to turn it off and a service charge applied to have it turned back on.

**Installation Cost** – The cost associated with establishing Irrigation/Pool Service is listed in the Fee Schedule.

## **2.9 Commercial Water Only Service**

Application for Commercial Water Only Service shall be made in the same manner as for Residential Service.

If the Commercial Water Only Service is 1” or less and to be a new tap or double head located at the domestic meter location, the meter and backflow device will be installed by MAWSS. Contact Mapping and Connections Department or refer to the fee schedule for current applicable fees. See MAWSS Cross Connection Policy for more information.

If the Commercial Water Only Service is to be a deduct meter(s) or wastewater meter(s) located on the customer’s property, the meter used shall be purchased, installed, and maintained by the customer. The make and type of the meter, as well as the location, shall be approved by MAWSS. The meter shall be tested, repaired and/or replaced by the customer, at the customer’s expense, if requested by MAWSS. The meters must be calibrated annually by a technician certified by the meter’s manufacturer. The certification must be provided to MAWSS annually on a schedule established by MAWSS. Failure to provide certification could result in termination of service or removal of the ability to use a deduct meter.

**Backflow Prevention** – An approved backflow assembly shall be installed in accordance with the Board’s Standard Specifications, a copy of which is available on MAWSS’ website.

The type of prevention device required will depend on the use of the Commercial Water Only Service. The type will be determined by MAWSS’ personnel after reviewing the application submitted and will be communicated to the customer. The customer shall furnish and install the



required device. Failure to properly install the required device will result in an interruption of service.

If Commercial Water Only Service is provided to a business where a floor drain has been installed as an emergency measure, a minimum sewer charge will be applied to the monthly bill even if the floor drain is not used.

**Billing** – The minimum monthly water charge will be billed for those months when the commercial water only meter is not used.

If a deduct meter is utilized, a monthly fee per meter read shall be charged to the account. See Fee Schedule.

If a customer wishes to have the meter turned off during the months it is not in use, a service charge will be required to turn it off and a service charge applied to have it turned on.

**Installation Cost** – Contact Mapping and Connections Department or refer to the fee schedule for current applicable cost associated with establishing Commercial Water Only Service. If a deduct meter is used, the customer shall purchase and install the meter and backflow device.

**Audit** – All customers applying for an Irrigation/Pool Service or a Commercial Water Only Service shall agree to an audit of their domestic and irrigation/pool systems, if requested by MAWSS.

Any customer violating the terms of this policy will be subject to a \$1000 charge and will forfeit any future right to an Irrigation/Pool or Commercial Water Only Service.

## **2.10 Right-of-Way Irrigation Service**

Application for Right-of-Way Irrigation Service shall be made in the same manner as for Residential Service, with the following additional conditions:

- The applicant shall provide to MAWSS acceptable evidence of approval from the appropriate governmental entity for the installation of a meter for irrigation purposes within the public right-of-way. The applicant shall also provide a billable party that is responsible for the monthly consumption charges for this service.
- As a public service to the community and at the discretion of MAWSS, the installation charges up to the amount of a standard service line connection fee charge for a 5/8-inch meter can be waived. Any installation costs exceeding the amount shown in the Fee Schedule shall be borne by the customer.
- An approved backflow prevention assembly shall be installed by the customer, on meters larger than 1" and in accordance with the Board's Standard Specifications, a copy of which can be obtained in accordance with provisions of Section 7.12.

## **2.11 Construction Phase – Temporary Service**

Application for water and/or sewer service during the construction phase shall be made in the same manner as for Residential Service with the following additional requirements:

Construction service may be granted for a limited period of time to a customer who is required to construct mains to serve his development, conditioned upon fulfillment by the developer of the requirements in Section 7 and any additional requirements which may be imposed by MAWSS. Developments include, but are not limited to: subdivisions, hotels, motels, office complexes, apartment complexes, shopping centers/malls, schools/universities or any large construction project that may require water for or during the construction process. To obtain Construction Service, the developer must:

1. Present MAWSS with evidence of approval from local, state, and federal governments. (Approved Construction Plans along with Applicable Permits)
2. Pay all fees and charges, in advance.
3. Execute a Restrictive Covenant acceptable for recording in the public records of Mobile County that unless the on-site/off-site improvements have been completed in accordance with the Board's Standard Specifications and accepted by MAWSS within 365 days from the date of such Covenant, permanent service may not be provided to the project and construction service will be subject to termination without notice.

MAWSS may authorize the use of temporary water for construction from meter(s) provided in developments that have not been accepted by MAWSS. MAWSS reserves the right to limit the number of meters for multiple building developments, to one meter per building. Permanent service shall not be provided until the water and/or sewer lines have been approved and accepted, as provided in Section 7.10.

Construction Phase – Temporary Service is limited to such use (construction only) and subject to immediate removal if service is used for any other purpose or for any site other than the one for which the meter is installed.

The customer shall be billed monthly at the prevailing user charge rates for service to the premises using the service.

MAWSS may authorize the use of water for construction from an existing meter to the premises subject to all current conditions governing the use of construction service.

## **2.12 Construction Phase – Permanent Meter Service**

Where a permanent meter has been installed during the construction phase but the service is used to facilitate construction and provide water for testing the plumbing only, the Construction Phase – Permanent Meter Service will apply.

The General Contractor will receive a monthly billing based on 5/8" meter consumption charges for water and sewer. In no case will the billing be less than the minimum monthly billing for a 5/8" meter.

The service will be provided to the General Contractor until the estimated project completion date or until the business opens to the customer, whichever comes first. An estimated date of completion is required to be provided to MAWSS. If the meter is needed for longer than the anticipated date of completion, the contractor will contact MAWSS to advise of the extended time needed, but in no case will the total time allowed be greater than 365 days. Once the estimated completion date has been reached, consumption will be charged at the correct meter size rate. No credits will be given to contractors who failed to request additional extension time and were billed at the higher rate.

In addition, MAWSS has no obligation to provide permanent service to a customer whose facilities have not been accepted by MAWSS.

### **2.13 Special Event Service**

MAWSS may authorize the use of water from an existing fire hydrant adjacent to the premises for certain special events (i.e. craft shows, circus, etc.) for a specific time period upon payment of a hydrant rental charge, payment in advance of the anticipated water use, and a security deposit to cover theft or damage to the meter and backflow assembly. Please reference the Fire Hydrant Meter Rental policy for additional information concerning fire hydrant meter rentals.

### **2.14 Fire Protection Service**

Application for Fire Protection Service shall be made in the same manner as for Residential Service, subject to the additional requirements noted in Section 7.8, "Fire Protection".

### **2.15 Grounding of Electrical Systems to Water Lines**

In an effort to ensure the safety of Board employees, and to minimize risk from exposure to electrical shocks while performing work involving leaking services, meter change outs, and repairs of any nature, customers are not to ground their electrical system to water lines. Any liability resulting in the grounding of an electrical system to the water lines will be the responsibility of the property owner.

### **2.16 Reservation of Rights**

The Board reserves the right to change its rates for service and other fees and charges or otherwise vary the terms and conditions of the Contract for Service as may be required to reflect the changing costs or otherwise facilitate the successful operation of MAWSS. The Board reserves the right to refuse service to anyone who has not complied with the Board's Standard Specifications, Policy and Procedures, Rules and Orders, or the provisions of local, state, or federal requirements, including the City of Mobile Plumbing Code.

## **2.17 Easements**

Any utility, person, cable company, City, County, State or other authority, either public or private, planning to construct any improvements over, on, upon, under, through and across Board easements shall do so only with written consent from and with just compensation to the Board. Any costs associated with removing said improvements from the easement to gain access to water and sewer facilities will be paid by the requestor. No fencing, buildings or similar permanent structures shall be erected on an easement.

## **2.18 Requirement to Take Both Water and Sewer Services, if Available**

When both water and sewer services are available, or MAWSS makes them available, customers must subscribe to both services. If only one service is available, MAWSS may provide only that service. If the service provided by MAWSS is sewer, and water is provided by private well or from another utility and MAWSS elects not to provide that service, MAWSS may provide sewer service and bill the customer according to the water consumption provided by the water utility or other means, or set a flat monthly rate not determined by individual customer consumption. MAWSS reserves the right to deny service if both water and sewer are available and a customer refuses to subscribe to both. MAWSS reserves the right to waive the above requirements. MAWSS reserves the right to discontinue either service, after proper notice, for failure to comply with the Policies and Procedures of the Board.

## **2.19 Grinder Pump Service**

When a property requires a grinder pump for sanitary sewer service, the pump shall be as follows:

- (1) If the grinder pump is connected to a gravity sewer line or is in a development with a low-pressure collection system served by a gravity sewer adjacent to the development, the pump shall be any of the accepted pumps listed in Appendix A, Part III, Submersible Grinder Pumps, of the Board's Standard Specifications.
- (2) If the grinder pump is in a development with a low-pressure system served by a force main that may serve other developments, the pump shall be a low flow/high head pump as listed in Appendix A, Part III, Submersible Grinder Pumps, of the Board's Standard Specifications.

Where it has been established that a customer of MAWSS: (1) does not have full use of their sanitary sewer due to excessive infiltration/inflow (I/I) in the MAWSS system, and the interference is expected to reoccur during heavy rain, or (2) must be removed from the gravity system due to a grade conflict or a fiscal decision, it is the policy of the Board to assist that customer with the cost of installing a pressure sewer system. The customer agrees upon acceptance of this assistance offer to solicit quotes from three licensed plumbers and to contract with the low quoting plumber to complete the installation within 60 days. The assistance will be disbursed upon receipt of the three quotes and an inspection certificate from the appropriate jurisdiction. The Board will not be responsible for maintaining the grinder station.

## **2.20 Wastes Delivered Directly to Wastewater Treatment Facilities**

To safeguard the performance of treatment processes and facilities, acceptance of wastes delivered directly to MAWSS' wastewater treatment facilities may be considered on a case-by-case or waste category basis. A decision regarding the acceptance or rejection on a case-by-case or waste category basis shall be made by the MAWSS' Board. If a waste is accepted, it must be accompanied by a contractual understanding of the character and quantity of the waste, waste delivery conditions, and fees. Some wastes may require pretreatment prior to acceptance by MAWSS. The expense of correcting any damage to MAWSS' wastewater treatment facilities or processes by a directly delivered waste hauler or waste shall be borne by the waste hauler. Initial acceptance by MAWSS shall not guarantee continued acceptance. MAWSS shall have the right to suspend acceptance of direct delivery waste for any reason.

## **2.21 Decentralized Systems**

Various subdivisions using MAWSS' services are served by a treatment and disposal facility as well as septic tanks serving the individual homes. These systems are referred to as Decentralized Systems. MAWSS will operate and maintain the collection system, which consists of the septic tanks, its pump, and the electrical equipment for the pump. This maintenance will include pumping the septic tank as necessary. Homeowner agrees to allow MAWSS and/or its designated contractor, and their employees, permission to come onto the property and to have free access to the collection system for operation and maintenance. Homeowner agrees not to construct or place items, structures, trees or shrubbery, or anything else over or on top of the collection system in such a way as to impede MAWSS in its efforts to operate and maintain the collection system. MAWSS has the right to remove any items which impede access to the collection system. Any electric power for the collection system septic tanks pump will be furnished with the electric power service to the customer's property and is the customer's responsibility.

MAWSS will not be responsible for any personal injuries or damages to the customer's property including but not limited to the home and its contents as a result of a power failure or pump malfunction; and the customer in accepting service, indemnifies and holds harmless MAWSS for the same.

Homeowner is not to install a garbage disposal in the home and agrees not to dispose of grease or other kitchen waste solids into the sewer or collection system. Homeowner understands and agrees that damage to the collection system or excessive maintenance caused by the homeowner or anyone else will be billed to the Homeowner. It is the Homeowner's responsibility to immediately notify MAWSS of any problems with the collection system serving their property.

## **2.22 Backflow Prevention Requirements for Water and Fire Line Services**

**See Cross Connection Control policy.**

**SECTION 3**  
**FEES AND CHARGES**

**3.1 General**

Rules, charges, and fees for services provided by MAWSS are established by order of the Board and are contained in the current MAWSS' Fee Schedule, as modified from time to time by the Board. Copies of the current Fee Schedule may be inspected at MAWSS' office and are available free of charge upon request. They are also available on MAWSS' website. All fees are payable in advance of service. At the discretion of the Board, some one-time fees may be paid in installments.

Public Schools, K through 12, shall be charged 70% of the water charges (water used for irrigation or sports facilities are excluded) during 2023. During 2024, they will be charged 85% of water charges. Starting in 2025 and thereafter they will be charged 100% of water charges. Public Schools (colleges and universities) shall be charged 100% of the water charges (water used for irrigation or sports facilities are excluded) starting in 2023.

**3.2 Service Fees & Charges**

The Service Fees & Charges is comprised of a "capacity fee," "service line installation (tap) fee," and a "service line connection fee."

**Capacity Fee:** The capacity fee is charged to new and existing customers who modify, add, or construct facilities which impose additional potential demand on the water and/or wastewater system. This fee is charged to equitably adjust the fiscal burden of water/sewer users. All capacity fees are allocated to the direct and indirect costs of capital improvements made necessary by actual and expected increased demand on the water/sewer system.

A baseline value for the capacity fee is established for a 5/8-inch water meter size. All other meters, except 5/8-inch irrigation meters, will be charged a capacity fee based on an ERC meter size, as related to a 5/8-inch meter as follows:

<u>METER SIZE</u>	<u>ERC</u>
5 / 8"	1.0
3 / 4 "	1.5
1"	2.5
1.5"	5.0
2"	8.0
3"	16.0
4"	25.0
6"	50.0
8"	80.0
10"	115.0

The capacity fee is in addition to any amount which might be expended by the customer for water/sewer system improvements or other fees required by MAWSS. The capacity fee is not refundable.

MAWSS reserves the right to discontinue service to premises for non-payment of applicable capacity fees. MAWSS reserves the right to charge the capacity fee on the basis of meter size for those users who impose a potential demand greater than can be supported by a 5/8-inch meter. The right to service, as applicable to the capacity fee, is assigned to the premises served and is not transferable.

A separate record shall be maintained for all capacity fee receipts, and the revenues so realized shall be restricted in the application as provided for herein.

Additional capacity fees may be charged to a customer who modifies or changes the use on the premises served, including the reduction of dwelling units, which may result in a greater equivalent ERC. For capacity fees that are increased, credits will be given for capacity fees paid for previous use.

Additional meters may be installed on a single line serving a single lot with an additional charge levied for each meter installed, including additional capacity fees where applicable.

Sewer connection fees for single-family residential customers, (who own and are/will be living in the residence), may be financed for a period not to exceed five (5) years at the interest listed on the Fee Schedule.

**Service Line Installation (Tap) Fee:** The Service Line Installation (Tap) is the process of installing a water service line and/or sewer lateral from the main line to the property line.

The Service Line Installation (Tap) fee for water is based on size as shown on the Fee Schedule. The Service Line Installation (Tap) fee for sewer is a fixed rate as shown on the Fee Schedule.

**Service Line Connection Fee (includes meter):** A Service Line Connection Fee is charged for costs incurred by MAWSS in the connection of the customer's premises to MAWSS' water or wastewater system via existing service line or lateral and will vary with the size of meter or pipe installed. Service Line Connection fees generally are charged to customers requesting additional service connections. Service Line Connection fees shall be charged for each change in the size or type of meter, and include an initial service charge, the cost of labor and materials, permit costs, and use of equipment for the installation of the meter, related fittings and appurtenances, and replacement of pavement, sidewalk, curbs, gutters, sod, and plantings, if required.

Additional meters may be installed on a single line serving a single lot with an additional charge levied for each meter installed including material, labor, equipment, and overhead, together with additional capacity fees when applicable.

Renewals of ¾-inch water service lines are at the customer's request and expense.

Sewer laterals shall be installed and maintained at the owner's expense from his property line to the structure served. Owner is responsible for clearing any blockages that may occur in the sewer service line from the structure served to the sewer main.

### **3.3 Surcharge**

Sewage exceeding the equivalent of domestic or normal strength sewage is considered “high strength sewage”, usually generated by industrial and commercial customers. A surcharge is imposed on those customers generating high strength sewage. This charge is for the recovery of the extraordinary operation and maintenance costs associated with the treatment of such high strength sewage. See Fee Schedule.

A surcharge is imposed for the following:

1. BOD in excess of 280 parts per million (ppm)
2. Suspended solids in excess of 250 ppm
3. Oil and grease in excess of 100 ppm
4. Ammonia Nitrogen in excess of 20 ppm

### **3.4 Meter Test Fee**

Upon written request and advance payment of a Meter Test Fee, as shown in the Fee Schedule, MAWSS shall test a customer’s meter to prove its accuracy. The Meter Test Fee will not be refunded to a customer with a meter that registers equal or less than the actual amount of water passing through the meter.

### **3.5 Tampering Charge**

Upon receipt of notification by either an individual or employee of MAWSS that there is reasonable cause to suspect that tampering with MAWSS’ property or facilities has occurred at any premises served by MAWSS, MAWSS shall cause an investigation to be made of those premises. If an on-site inspection verifies tampering, MAWSS shall charge an initial Tampering Charge to cover its expenses in conducting said investigation and taking measures to deter further tampering. Any repeat occurrence(s) of tampering with MAWSS’ facilities will result in the application of a repeat Tampering Charge and the abandonment at the main of all service(s) to the premises for which restoration of service would include the payment of Connection Charges. The Tampering Charge and the repeat Tampering Charge amount shall be established by order of the Board. If it is reasonably established that the individual who has tampered with MAWSS’ facilities is the same person who resided at the site at the time of the tampering, then that individual will be responsible for the tampering charge and all other appropriate charges unless that individual can demonstrate that another party is responsible for the tampering.

### **3.6 Service Charge**

A Service Charge is charged by MAWSS for each instance in which water service is connected, for the collection of a delinquent account or dishonored check, tampering, vandalism, etc. and for subsequent on-site visits resulting from these and other-related causes not in the usual course of scheduled business. In the case of a divorce or where a spouse is deceased, the service charge will be waived unless the service has been cut or discontinued. Service provided between normal business hours of the next business day shall be considered Regular Service. Service provided between normal business hours on the same business day shall be considered Priority Service.



Service provided between normal business hours and/or on weekends and holidays shall be considered Priority Service. See Fee Schedule for applicable rate.

### **3.7 Delinquent Account Charge**

The Board shall impose a Delinquent Account Charge as provided in Section 4.10.

### **3.8 Return Check Charge**

MAWSS shall impose a Returned Check Charge for each dishonored check that is returned by the bank. Only cash, cashier's check, or money order will be accepted as payment for checks which have been dishonored. The customer's account will be annotated upon receipt of a dishonored check. The issuance of the second dishonored check will preclude the acceptance of another check for a twelve-month period. During this time, only cash, cashier's checks, or money orders will be accepted for payment.

### **3.9 Refunds of Overpaid Service**

Overpayment of service on an active account will be refunded only at the request of the customer. Refund checks are issued once a month. Should a customer request payment prior to the scheduled refund date, a processing fee will be deducted from the amount of the refund.

### **3.10 Meter Relocation**

Meters will be relocated by MAWSS at the owner's request or when it is in the best interest of MAWSS. The cost of this relocation when performed at the owner's request will be billed to the owner. It is the owner's responsibility to have the meter connected to their line.

### **3.11 Easement / Right-Of-Way / Vacation Charge**

Customers requesting an easement or right-of-way vacation shall pay the scheduled fee to cover the cost of researching the necessary documentation to make the vacation ruling. The fee is required when the vacation request is made and is non-refundable. Easement and right-of-way vacation requests should be directed to the Mapping and Connections Department of MAWSS.

### **3.12 Development Review and Inspection Fee**

The scheduled development review and inspection fee shall be paid by those individuals requesting reviews for commercial subdivisions, residential subdivisions, and commercial developments. The fee shall be provided at the time the review is requested. The comments provided by MAWSS as a result of a plan review shall remain valid for a period of two years (730 days) from the date that MAWSS provides the final comments of said review to the requester. Re-submittals of plans for review during this two-year period shall be charged the scheduled fee for plan review re-submittal. The two-year period of validation shall begin at the date that MAWSS provides final comments on the re-submittal review. After the two-year period, the plans must be

resubmitted for review if the requester has not commenced with constructing the project disclosed in the plans. Total fees shall be charged for plans that are resubmitted after the two-year period. MAWSS will provide a checklist of items required for submittal prior to acceptance of any water and sewer facilities. All submittals shall be given to the appropriate MAWSS inspector, who will ascertain the completeness of the submittals. The MAWSS inspector will also make periodic site visits during construction to confirm adherence to the Board's Standard Specifications.

### **3.13 Locate Sewer Service Connection (Lateral Location)**

Plumber (or property owner) is expected to exert reasonable effort in locating sewer laterals. Any lateral that is within 5 feet of the horizontal location indicated by the Board's Mapping and Connections Department and at a depth within 8 feet of the original ground level will be considered accessible. There is no charge for the initial lateral verbal location information provided by the Mapping and Connections Department. However, if plumber (or property owner) requests a lateral location by videotaping and/or excavation, they will be billed the scheduled amount for videotaping and/or excavation if the lateral is found to be accessible.

A fee shall be charge for MAWSS to physically locate a sewer lateral either by video or excavation methods. Measurements can be given at the request of a builder, homeowner, or plumber except in cases where the record utility drawings are lacking that information. See Fee Schedule for established amount.

### **3.14 Property Owner Sewer Repair Notices**

Defective Private Property Sanitary Sewer Laterals (Private Laterals), which extend from private buildings and facilities to the public sanitary sewer system, and private lateral cleanouts, which provide access to said laterals for maintenance, are major contributors of Storm Water to the public sanitary sewer system during rain events. Storm Water is detrimental to the public sanitary sewer system in the following ways: 1) it causes wet weather sanitary sewer overflows (SSOs); 2) it causes sewer backups into buildings; 3) it decreases system capacity for transporting and treating wastewater; 4) it decreases capacity for connecting new customers; and 5) it requires costly upgrades to wastewater collection and treatment systems. Consequently, property owners are required to maintain their laterals in a state of good repair so that defects do not allow storm water to inflow and infiltrate (I/I) into the public sanitary sewer system. Customers of MAWSS agree to prevent their plumbing from being I/I sources as a condition of continued service by MAWSS.

MAWSS performs inspections and testing in parts of the sewer collection system where excessive inflow *and/or* infiltration have been measured. The work is performed to identify whether storm water or groundwater can enter the sanitary sewer system through defects in the Board's sewer mains and laterals or through the sewer services on private property or both. This policy prompts property owners to repair and properly maintain private laterals and clean-outs, as well as remove any other sources of I/I, such as roof downspouts connected to the sanitary sewer system and unauthorized surface drains.

If inspection or testing (via industry accepted measures) indicates that a sewer service on private property is defective, the property owner and tenant (if applicable) will be notified by certified letter. The property owner will be given 180 days to have the private property sewer defects located and repaired by a licensed plumber and to notify MAWSS of the repairs. For verification

purposes only, the property owner shall send a copy of the plumber's bill to MAWSS with a statement that the repairs have been made. MAWSS will not pay the plumbing bill. MAWSS may, at its option, re-test the line to verify that all defects have been repaired.

If the property owner fails to notify MAWSS within 180 days that the repairs were made within the allotted timeframe, the "Unauthorized Storm Water/Rainfall, Other Drainage Inflow into Sewage System Charge" shown in the Fee Schedule will be added to the water and/or sewer bill.

Any additional charges and/or penalties discussed herein are considered a part of the water and/or sewer bill. Failure to pay these charges will result in a delinquent account and action will be taken by MAWSS as discussed in Section 4.10, "Delinquent Account." Non-payment of the entire bill may result in service being discontinued within 42 days of the original bill date.

There are three categories of lateral owners identified in this program: 1) a resident property owner who owns and resides in the single dwelling served by the defective lateral; 2) a MAWSS customer landlord who owns rental property served by the defective lateral and is a MAWSS customer elsewhere in the service area; and 3) a non-MAWSS customer landlord who owns rental property served by the defective lateral and is not a customer of MAWSS. This category includes rental property owned and/or managed by management companies and other such corporations, LLCs, partnerships, etc.

To ensure property owners will repair their defective laterals, the following actions will be taken:

1. Resident Property Owner – If the repairs are not completed within 180 days of initial notification, a monthly penalty will be billed for up to 90 days. Should repairs not be completed after the first 90-day period of penalties, the monthly penalties will double for an additional 90 days. If the lateral is not repaired after 360 days, water and/or sewer service will be discontinued at the address of the defective lateral.
2. MAWSS Customer Landlord – If the repairs are not completed within 180 days of initial notification by MAWSS, a monthly penalty will be billed to the landlord's private water and/or sewer account for up to 90 days. Should repairs not be completed after the first 90-day period of penalties, the monthly penalties will double and continue to accrue to the private water account until the lateral is repaired or the tenant vacates the property. If the tenant vacates the rental property served by the defective lateral, water and/or sewer service to the rental property will be discontinued until all accrued penalties and fees are paid and lateral repairs are completed. If the landlord accrues penalties to his/her private water account and fails to pay said penalties, the account becomes delinquent and water/sewer service will be cut at the private address of the landlord. To re-establish service to the landlord's private account, all fees and charges in accordance with the Delinquent Account Policy must be paid at the private address. After five months of penalties, the City of Mobile's Chief Plumbing Inspector will be notified of the defective lateral. The City may take additional actions to ensure the lateral is repaired. Regardless of actions taken by the City, penalties will continue to accrue until the lateral is repaired.
3. Non-MAWSS Customer Landlord or Property Management Company – If the repairs are not completed within the initial 180 days of initial notification by MAWSS, a billable

account will be created for the property owner or management company. Monthly penalties will be assessed to the account for up to 90 days. Should repairs not be completed after the first 90-day period, the monthly penalty will double and continue to accrue until the lateral is repaired or the tenant vacates the property. If the tenant vacates the rental property served by the defective lateral, water and/or sewer service to the rental property will be discontinued until all accrued penalties and fees are paid and lateral repairs are completed. After five months of penalties, the City of Mobile's Chief Plumbing Inspector will be notified of the defective lateral. The City may take additional actions to ensure the lateral is repaired. If the MAWSS penalties are not paid for six billings, the account will be forwarded to a collection agency. Any outstanding penalties will be pursued through the collection agency. Regardless of actions taken by the City or the collection agency, penalties will continue to accrue until the lateral is repaired.

Should MAWSS determine that repairs have not been made to the lateral as indicated by the property owner, the property owner will be notified that the lateral is still in need of repair. If the 180 days has not expired, the remaining time will resume from the date MAWSS re-notifies the property owner that the lateral still needs repairs. If the 180 days has expired, the property owner will be assessed the "Unauthorized Storm Water/Rainfall Inflow into Sewage System Charge." The sequence of fees and potential loss of service will occur as described above.

MAWSS may re-test the line to verify that all defects have been repaired at any time.

## Private Lateral Cleanouts

If inspection or testing (via industry accepted measures) indicates that a private lateral cleanout cap is not in place, MAWSS will leave a cleanout cap package at the property (once per property ownership). The property owner will be given 7 days to replace the cleanout cap. After 7 days, MAWSS will inspect the property to ensure the cap has been installed. If the cap is not installed after 7 days, the property owner will be notified by certified letter that a cleanout cap package was left at the property and needs to be installed. The property owner will be given 30 days to install the cleanout cap and notify MAWSS of the installation. If the cleanout cap is not installed within 30 days, the following will occur:

1. Residential Property Owner – If cleanout cap is not installed within the initial 30 days, a monthly penalty will be billed for up to 90 days. Should the cap not be installed during the 90-day penalty period, water and/or sewer service will be discontinued at the address in question.
2. MAWSS Customer Landlord - If the cleanout cap is not installed within the initial 30 days, a monthly penalty will be billed to the landlord's private water and/or sewer account for up to 90 days. Should the installation not be within the first 90-day period, the penalty will double and continue to accrue to the private water account until the cap is installed or the tenant vacates the property. If the landlord accrues penalties to his/her private water account and fails to pay said penalties, the account becomes delinquent and water/sewer service will be cut at the private address of the landlord. To re-establish service to the landlord's private account, all fees and charges in accordance with the Delinquent Account Policy must be paid at the private address. After five months of penalties, the City of Mobile's Chief Plumbing Inspector will be notified of the defective lateral. The City may take additional actions to ensure the lateral is repaired. Regardless of actions taken by the City, penalties will continue to accrue until the lateral is repaired.
3. Non-MAWSS Customer Landlord or Property Management Company – If the cleanout cap is not installed within the initial 30 days, a billable account will be created for the property owner or management company. Monthly penalties will be assessed to that account for up to 90 days. Should repairs not be completed within the first 90-day period, the monthly penalty will double and continue to accrue until the cap is installed or the tenant vacates the property. If the tenant vacates the rental property served by the defective lateral, water and/or sewer service to the rental property will be discontinued until all accrued penalties and fees are paid and lateral repairs are completed. After five months of penalties, the City of Mobile's Chief Plumbing Inspector will be notified of the defective lateral. The City may take additional actions to ensure the lateral is repaired. If the MAWSS penalties are not paid for six billings, the account will be forwarded to a collection agency. Any outstanding penalties will be pursued through the collection agency. Regardless of actions taken by the City or the collection agency, penalties will continue to accrue until the lateral is repaired.

Should MAWSS determine that the cleanout cap has not been installed as indicated by the property owner; the property owner will be notified that the cleanout cap still needs to be installed. If the 30 days has not expired, the remaining time will resume from the date MAWSS notifies the property owner that the cap is not in place. If the 30 days has expired, the property owner will be

assessed the “Unauthorized Storm Water/Rainfall Inflow into Sewage System Charge.” The sequence of fees and potential loss of service will occur as described above.

MAWSS will only provide a cleanout cap package once per property ownership and may inspect the cleanout at any time to ensure the cleanout cap remains in-place.

### **Other Sources of I/I**

Any other private property sources of I/I, such as, but not limited to, roof downspouts, sump pumps and unauthorized surface drains, will be addressed in accordance with either the Private Laterals or Private Lateral Cleanouts provisions above. The approach used will depend on the cost and complexity of removing the I/I source.

### **Leased or Rented Property - Notification of Owner by Tenant**

Where a property is leased, MAWSS will make an effort to contact both the property owner and tenant. There are times when the property owner is difficult to locate; therefore, the tenant shall also be required to contact the property owner and notify him/her of the needed repairs to remove I/I sources from the premises.

Compliance with this policy is a condition of service. MAWSS reserves the right to seek reimbursement of administrative and operational costs, collection costs, and legal fees resulting from enforcement of this policy. Property owner agrees, as a condition of MAWSS furnishing service to the property, that MAWSS recover these costs and fees if property owner fails to comply with this policy.

### **3.15 Termination of Sewer Service by MAWSS**

Property owners who are three months delinquent in paying their sewer bill will have their sewer lateral cut and plugged so that sewer service is no longer available. Once a lateral is cut and plugged, the property owner must pay the “Unplugging Sewer Only Lateral” fee before the sewer service can be reconnected plus any delinquent billing amounts owed. If a lateral is scheduled to be cut and plugged, the property owner may prevent the cutting and plugging by paying the delinquent amount of the bill plus the mobilization fee shown in the Fee Schedule. The property owner must visit MAWSS and pay the delinquent bill prior to the schedule date the crew is to arrive to cut the sewer lateral.

At locations where there are multiple dwellings on one sewer lateral, such as an apartment complex, and the tenants of each unit are required to pay their own water and sewer bill, the manager or owner of the complex will be billed for those tenants who are delinquent in paying their water and sewer bill.

If sewer service is cut and plugged because a tenant failed to pay his or her bill and said tenant vacates the property leaving the sewer account delinquent, the property owner will be responsible for paying the “Unplugging Sewer Only Lateral” fee.

If sewer service is cut and an elder valve is in place, the service may be re-established by paying the fees for both cutting and reconnecting the service plus any delinquent billing amounts.

It is the property owner’s responsibility to verify functionality of the existing sewer service lateral. MAWSS assumes no liability for property damage resulting from using a defective or capped

sewer lateral. The property owner will be responsible for paying the scheduled fee to reconnect/unplug a sewer lateral.

Properties that have been abandoned and/or unoccupied for more than five (5) years may have the sewer service capped by MAWSS. Reinstatement of service will require payment of all normal fees associated with a new service.

### 3.16 Basis of Unit Charges – Multiple Units

Customers require water and sewer service capable of responding to a wide variety of demand on use. Though the divergent use pattern of a large number of customers reduces the relative range demand capability needed, a significant portion of the resources of the system remains necessary for stand-by demand.

The costs of these resources are recovered through a water rate structure that declines with increased use. By having a higher water rate for the first water used each month the cost of stand-by capability is spread among all units of customer use. The accounts with units are charged the greater of the prorated costs of the average individual consumption times the number of units or the consumption costs, whichever is greater. The consumption calculation will check for minimum consumption.

For the greatest number of MAWSS' customers the number of units receiving service is one, and there is no reason to give any attention to the unit charges. However, for customers listed in the following table the unit charge policy is significant.

	<u>Type of Customer</u>	<u>Explanation</u>	<u>Units</u>
1	Single family residence	---	1.0
2	Each rental unit in a multi-family complex	Occupied or Vacant	1.0
3	Each 4 rooms (or part thereof) of hotel or motel rooms or suites	Occupied or Vacant	1.0
4	Number of trailer space outlets in a park with a master meter	Occupied or Vacant	1.0
5	Number of businesses having separate restrooms in an office complex or building	Occupied or Vacant	1.0
6	Each 8 rooms (or part thereof) in an office or industrial complex or building having common restrooms	Occupied or Vacant	1.0
7	Each part of any shopping center used by separate tenants whether under one roof or more roofs	Occupied or Vacant	1.0

Fire line charges will be divided among active businesses that have water accounts in publicly owned buildings served by a fire line common to those businesses.

### **3.17 Fire Hydrant Meter Usage**

Customers desiring the use of water from a hydrant may obtain permission by completing required forms and paying established fees. The hydrant meter may only be used on a MAWSS hydrant. If the meter is lost or stolen, the customer will be required to pay for the cost of a replacement meter and the cost of fittings and forfeit the deposit.

MAWSS reserves the right to deny future rental to customers that are found to have misused the fire hydrant meter.

### **3.18 Go Back / Turn On Charge**

When a customer requests MAWSS come out to turn their meter on, the customer must be present to authorize service. If the customer is not present, thereby requiring MAWSS to make a return trip, a service charge will be incurred. Customer may turn on service to prevent a return trip service charge.

### **3.19 Meter Reread Fee**

Each time a customer requests that their water meter be reread and the initial reading is found to be correct, a "meter reread fee" as listed in the Fee Schedule will be charged to the customer's account. If the reread indicates that the initial reading was incorrect, the customer will not be charged a fee.

### **3.20 Dormant Account Charge**

This service charge applies to all customer accounts which discontinue service, have money due them, and which leave no traceable forwarding address. MAWSS will make every reasonable attempt to locate the customer within a five-year period. A holding charge as shown by the Fee Schedule will be applied to the account annually for five years. After this time, any balance remaining that is greater than (\$50) will be transferred to the State as unclaimed property.

### **3.21 Charge to Uncover or Access a Water Meter**

All meter boxes are to be kept free from vegetation and debris. The meter box must be easily accessible for reading and maintenance. In the event a meter box is inaccessible for 3 two (2) or more consecutive months, whether intentionally or by accident, the customer will be assessed an amount equal to the cost incurred by MAWSS to uncover the box in addition to an estimated monthly usage charge.

Failure to maintain access to the meter for meter reading/servicing will result in a service charge, installation of a radio read device at customer's expense, and/or disconnection.



### **3.22 Third Party Damage to Sanitary Sewer Pressure Services**

Low-pressure sewer systems have been subject to third party breaks resulting in Sanitary Sewer Overflows (SSOs). Some of these breaks have occurred as a direct result of home building activity. The homebuilder is required to protect the pressure service at all times and is responsible for breaks due to home building activities, including site work. A break may result in an illegal discharge of sanitary sewer which may damage the environment and may result in a fine charged to MAWSS by regulatory agencies.

When a pressure service line is damaged by home building related activities, the following shall apply:

- 1) All costs incurred by MAWSS for repair and cleanup after damage occurs shall be billed to the homebuilder, including any penalties/fines imposed by regulatory agencies. This shall apply to the first occurrence of breakage by a homebuilder.
- 2) The second time a homebuilder is responsible for damage to a pressure service line, he shall pay the costs described in 1) plus an additional penalty of \$250.
- 3) The third time a homebuilder is responsible for damage to a pressure service line, he shall pay the costs described in 1) plus an additional penalty of \$500.
- 4) The fourth and any subsequent times a homebuilder is responsible for damage to a pressure service line, he shall pay the costs described in 1) plus an additional penalty of \$1000.
- 5) If the homebuilder has established a MAWSS service account for a home under construction, the water and sewer bill will remain in the homebuilder's name until any and all charges made in accordance with this policy are paid. Where MAWSS does not provide water service, sanitary sewer service will not be permitted until all charges are paid.
- 6) The homebuilder will not be issued any other meters until all charges made in accordance with this policy are paid.

### **3.23 Third Party Sanitary Sewer Overflow Costs**

When an SSO from MAWSS' wastewater facilities are the result of a negligent act by a third party and the third party can be identified, the cost of MAWSS' response to the SSO and any regulatory penalties associated therewith shall be invoiced to the third party. Refer to Policy 3.23 for SSOs related to sewer pressure services.

### **3.24 Fire Line Abandonment or Repair**

When an existing structure served by a fire line is demolished, a written request by the property owner must be submitted prior to MAWSS' abandonment of the fire line. Proof of demolition of the existing structure and a letter from the Fire Marshall authorizing the disconnection of the fire protection facilities must be attached. The requesting customer shall pay MAWSS' costs to permanently disable the line. Until such time the fire line is capped, property owner shall pay the monthly fire line charge.

When customer requests a fire line to an existing structure be turned off for a temporary period of time, a letter from the Fire Marshall authorizing the disconnection of the fire protection facilities

must be attached to the customer's written request. Requesting customer shall pay MAWSS' cost to provide this service.

### **3.25 Sewer Flat Rate**

MAWSS may impose a flat rate for its sewer only customers. Rules, charges, and fees for services provided by MAWSS are established by order of the Board and are contained in the current MAWSS' Fee Schedule, as modified from time to time by the Board. Copies of the current Fee Schedule may be inspected at MAWSS' office and are available free of charge upon request. There also available on MAWSS' website. All fees are payable in advance of service.

## **SECTION 4 BILLING AND PAYMENT FOR SERVICE**

### **4.1 Billing Period; Due Date; Evidence of Consumption**

Water/sewer meters shall be read and customers billed on a monthly basis. Billing will commence upon the installation date of a meter or service connection. If MAWSS is unable to read the meter, the reading will be estimated based on prior usage.

Payments for services are due upon rendition of the bill. Non-receipt of a bill by the customer shall not release the customer from the duty to make reasonable inquiry as to the amount of the bill and prompt payment thereof, in accordance with the customer's billing cycle.

The amount billed monthly (where applicable) shall include charges for: 1) water use; 2) sewer use; 3) surcharges; 4) fees; 5) taxes; and 6) charges. The amount of water/wastewater registered by the meter shall constitute evidence of the quantity of water delivered to, or the amount of wastewater discharged by, the customer.

Customers may access their bill by logging onto the MAWSS website at [www.mawss.com](http://www.mawss.com) and going to the section on "Bill Pay", "MAWSS eBilling". This is a free service which allows the customer to view their monthly bill and provides the option to pay online, if desired.

### **4.2 Use of Master Meters**

The Point of Delivery is the master meter. Any deduct or individual services that may exist beyond the master meter are subject to disconnection of service through the master meter if the master meter account is not in a current payment status, notwithstanding the current payment status of the individuals served beyond that master meter. The monthly deduct meter fee shown in the Fee Schedule shall apply to each additional meter used to determine water use in series with a master meter.

### **4.3 Description of Monthly Billing Charges; Minimum Stand-By Charge**

Monthly minimum billing charges are shown in the Fee Schedule, as established by the Board.

Within six months of any customer having both water and sewer service available from MAWSS, any customer not connected to both services shall be charged the minimum fee for the unused service in addition to the basic rate for the used service.

The stand-by charge shall be collected until the customer connects to the system and pays appropriate connection charges. The customer connecting to the system will receive a discount equal to the amount paid towards the total connection charges collected from that customer, not to exceed the amount of the connection charges then in effect.

In no case shall a customer be charged for both water and sewer services where only one of these services is available.

#### **4.4 Basic Water Rate**

A Basic Water Rate for treated water is shown in MAWSS' Fee Schedule and shall be paid by each unit customer of MAWSS.

#### **4.5 Basic Sewer Rate**

A Basic Sewer Rate for the collection, treatment and disposal of wastewater shall be paid by each unit customer of MAWSS, as shown in the Fee Schedule.

#### **4.6 Untreated Industrial Water Rate**

An industrial rate is charged to customers using raw, untreated water. The rates shall be applied to the total volume used during the preceding month.

The industrial water rates shall be adjusted annually to reflect the Board's actual cost to provided industrial raw water service. Until such time that separate rates are developed, the rates shall be the same for raw water supplied from any MAWSS water source; Converse Reservoir, Salco Lake, or other Mobile River sources. Raw water will be furnished from any source at the discretion of the Board. The Board, however, will comply with customer requests for water from a specified source provided the customer pays any additional costs for providing same.

At its option, MAWSS may sell treated water as a substitute for raw water at a rate to be determined by the Board, but in no case shall the rate be less than the cost of delivery of such water. Any such sale will be under the condition that as soon as raw water becomes available, the treated water supply will be terminated.

MAWSS is not obligated to provide raw water, but will negotiate with any interested party to extend the raw water delivery system to provide this service wherever practical and within economic feasibility.

#### **4.7 Fire Service – Stand-by Charge**

All customers with a fire protection service system, as defined in Section 7.8, shall be charged a stand-by charge monthly for fire service systems, as established by the Board, which shall be:

1. Based on the diameter of the pipe serving the fire protection service system.
2. Considered as a charge by MAWSS for maintaining the capacity to serve the fire protection system.
3. Assessed for the amount of water consumed by the customer, in addition to the Fire Service – Stand-by Charge monthly service charge, for installation for fire/domestic dual service.

#### 4.8 Installation of Irrigation Meters in Public Common Areas

Upon receipt of a request for installation of an irrigation meter on public common area property, MAWSS will proceed with the installation at a cost to the Board of no more than the Public Common Area Irrigation Meter Installation Allowance (add to fee schedule @ \$350) as shown in the Fee Schedule. The requester must agree to pay the difference in the actual cost of the installation and the allowance paid by the Board. The actual cost will include any costs associated with the installation such as permits, etc. The requester must also agree to pay the monthly water bill and pay a deposit for a new account.

#### 4.9 Customer Deposits

MAWSS requires each customer to place on deposit a cash amount, indemnity bond, or letter of credit which shall be established by order of the Board. No deposit shall be less than the amount established by the Board for a residential account. Residential deposits are identified in Section III of the Board's Fee Schedule. The customer deposit provides security for payment of amounts due to MAWSS. Existing accounts without deposits will be charged a current deposit if any change is made to the account.

For commercial accounts, the deposit shall be the amount shown in Section III of the Board's Fee Schedule. After a period of twelve months, MAWSS shall review the customer's payment history and if the customer has been delinquent during the year or if the average billing consumption amount is greater than the current deposit on file, MAWSS may elect to raise the deposit based on the actual billed amount. Those deposits exceeding this actual billed amount will remain the same.

MAWSS shall reserve the right to increase the deposit for customers with previous delinquent account histories. Those customers who are disconnected for non-payment two or more times in a twelve-month period are subject to an increased deposit requirement of an additional \$100. This amount will automatically be added to the total reconnection cost. Customers with previous delinquent account histories are required to pay a deposit and any installation charges prior to connection or transfer of service.

Deposits for Apartment/Multi unit complexes are calculated using the formula stated below. All deposits must be paid before service will be established.

#of units / 3 x 100 = deposit amount (rounded to nearest hundred if necessary for even amount)

Commercial Real Estate (Landlords, Developers, Builders, etc...) have the option to follow the deposit information listed above or can choose a blanket deposit that will cover all accounts. This blanket deposit criteria is listed below. Blanket deposits will be reviewed annually to determine if amount on file is sufficient to support the account and adjust accordingly.

0-5 Units	-	5 units /3 x 100=\$167
6-15 Units	-	15 units /3 x100=\$500
14-25 Units	-	20 units /3 x100=\$667
26 or more Units	-	26 units /3 x100=\$867

MAWSS will allow 10 days for receipt on all deposits. All commercial deposits may be in the form of cash, letter of credit, or bond.

#### **4.10 Delinquent Accounts**

An account shall be considered delinquent if payment for service, or other miscellaneous charges, is not received by MAWSS within twenty-two (22) days of the billing date. Delinquent accounts shall be charged a Delinquent Account Charge in the amount of ten percent (10%) of the total amount that is delinquent. Once the bill is delinquent, on the 45<sup>th</sup> day, a Delinquent Processing Fee will be imposed for the purpose of processing the collection of delinquent accounts (see fee schedule for rate). Any legal fees or charges by an outside source to collect payment will be the responsibility of the customer.

Once service becomes delinquent, it is subject to being discontinued/cut if the full amount of the delinquent bill plus any current billing is not paid within forty-five (45) days from the first billing date. Partial payment of delinquent accounts is not acceptable; the balance must be paid in full to avoid interruption of service. For service to be restored, the total bill must be paid, along with appropriate service charges or collection fees and deposit (if a deposit is currently not on file). Payment arrangements may be made with supervisory approval.

If a delinquent account shows to have a private lateral defect and service has been discontinued/cut, service will not be restored until repairs are made (see 3.15).

A customer with a delinquent account history requesting transfer of service to another location must pay in full all amounts due before new service will be established.

Payment of a delinquent account with a dishonored check shall result in immediate disconnection of service, subject to the provisions of Section 3.9.

Where service is provided to a fire protection system, as defined in Section 7.8, MAWSS reserves the right to discontinue the domestic or other non-fire related water service for delinquent fire line accounts, according to all procedures applicable to the collection of any delinquent account.

#### **4.11 Billing Disputes; Mistakes**

In the event of a billing dispute, the customer shall contact MAWSS' Customer Service office and request a review of the account. The account number, description of the premise served, nature of the dispute or alleged mistake, and date of contact shall be recorded by MAWSS. MAWSS will investigate the billing and expeditiously respond by letter, phone, or email. MAWSS shall not disconnect service or impose any charges for non-payment of the disputed amount while the dispute is under review, provided that such review commenced prior to the account becoming delinquent and as long as undisputed amounts are paid. Once the dispute is resolved, the customer shall have five business days to pay any disputed amount unless other arrangements are made.

#### **4.12 Abatement of Water and Sewer Bills**

MAWSS expects the water and sewer pipes and related fixtures on each customer's property to be protected, maintained, and operated by the customer and/or the property owner in a manner consistent with the customer's need for MAWSS' services. MAWSS' water and sewer rates are based on all customers paying for the services provided to them, and it is the policy of MAWSS not to refund or credit customer accounts for water charges for any service provided to the privately-owned plumbing system of any customer, regardless of whether the excessive use is caused by frozen pipes, improperly maintained or operated fixtures, corroded or faulty pipes, unauthorized use, or any other cause.

Residential customers may request a leak credit for the sewer portion one time during a twenty-four (24) month period if they can substantiate that they had a leak and this leak was repaired. Leak credits will not be issued for amounts less than \$50. The customer must request the credit within ninety (90) days of the date of the excessive bill and present evidence of expeditious repair or remedy. When a previous consumption history is unavailable, MAWSS will use 7,000 gallons as a monthly average for a residential user. For other users, MAWSS will use an average derived from similar users. MAWSS will only consider one abatement which will include the two highest bills resulting from the current problem.

Leak credits are issued on the sewer portion only of the two (2) highest bills. Water only accounts are not eligible for a leak credit. The customer is allowed a leak credit of 75% of the remaining sewer amount once the average sewer is subtracted from the high sewer amount. The 25% administrative fee is not to exceed \$200. This amount is only allowed if proof is provided that the leak did not enter the sanitary sewer. If there is no proof, the fee will remain at the 25% amount figured.

Credits will not be given for pools. Customers with pools are encouraged to purchase an irrigation meter to avoid being charged sewer fees on water used to fill pools.

#### **4.13 Tampering with Facilities**

Tampering with MAWSS' meters, water or sewer mains, or other system components is prohibited and in violation of Section 13A-8-10, Corrected Code of the State of Alabama. When tampering is discovered, MAWSS shall adhere to the following procedures:

MAWSS' employee will verify that tampering has occurred and witness the removal of any devices from the premises. Pictures shall be taken as any unauthorized devices are being removed.

When tampering has occurred after multiple offenses, MAWSS may sever service from the main lines to prevent a possible recurrence and notify the appropriate agencies. Prior to disconnection of service, MAWSS shall inform whatever person may be present at the premises at the time of such discussion of its intended action and the reason therefore. If no one is present, MAWSS shall place a door hanger at the premises which shall inform the customer of the action taken and the hearing provisions of this rule.

1. In cases of meter by-pass or reversal, or where the meter seal or lock has been broken, the account of the customer shall be back billed for the estimated amount of water consumed and not paid for. This amount shall be based upon:
  - (a) A charge for not less than the average water consumption or sewer service during the previous six active account months prior to the time such meter tampering is estimated to have occurred; or in the event the customer does not have a history of six active account months, a charge for not less than the average water consumption or sewer service for a customer served by MAWSS with a similar class of service during the most recent one year period for which such figures are available. When a previous consumption history is unavailable, MAWSS will use 7,000 gallons as a monthly average for a residential user.
  - (b) In the event a swimming pool is located on the premises, it will be presumed by MAWSS that said pool was filled with water diverted from the meter, and such amount shall be added to item "a" above. This presumption may be overcome by evidence of prior billed consumption of water necessary to fill the swimming pool during one billing period.
2. When the meter has not been disturbed, the customer shall be back billed for the amount of water consumed, as indicated by the meter, for which payment has not been received by MAWSS.
3. The Customer Deposit shall be increased for the customer to an amount equal to three times the average monthly billing during the previous twelve active account months, but not less than the minimum amount listed in the Fee Schedule, Customer Deposits. In the event the customer does not have a history of six active account months, the Customer Deposit shall be increased to an amount equal to three times the average monthly billing for a customer served by MAWSS with a similar class of service during the most recent one-year period for which such figures are available, but not less than the minimum amount listed in the Fee Schedule, Customer Deposits.
4. The customer shall be entitled to request a meeting with the Assistant Director or designated representative to be held no later than ten business days after the request. If the matter is not settled at the first meeting, the customer may, within 24 hours, request a second meeting which will be held before the Director or a designated representative no later than ten business days after the second meeting request. The determination by the Director or his designee shall constitute final MAWSS action and shall be made no later than two business days after the hearing.
5. MAWSS shall restore water and/or sewer service upon payment of all applicable service charges, tampering charges, back billing charges, Customer Deposit, and other amounts due.

MAWSS reserves the right to take such other, further, or different action as it may, in its discretion, determine. Further, the levy of charges shall not constitute a waiver of the right to prosecute such person or persons for theft of services.



#### **4.14 Credits Issued to Customers Billed for, but not Connected to the Sewer**

During 1993, the Board passed a Resolution adjusting water and sewer rates and fees whereby separate rate structures were established. A minimum fee for unused service for these customers connected to one service, but not connected to both services, was established.

If a customer requests a refund of charges billed due to service not being used, MAWSS will verify that the service is not connected. If service is available but not in use, the refund amount will be the difference between the sewer billed and the minimum charges for sewer. If sewer service is not in use, a refund will be issued for up to three (3) years prior to the date of the request, plus any addition billings since the request was made. Under no circumstances shall a refund be given on billed amounts prior to the three (3) years, unless approved by the Director or Assistant Director.

#### **4.15 Wholesale Water Service**

MAWSS provides wholesale potable water to other water companies. Charges are based on rates published in Section F of the Fee Schedule of the Policy and Procedure Manual. Rates are intended to cover all costs to MAWSS to distribute the water to the requesting system.

#### **4.16 Wholesale Sanitary Sewer Service**

MAWSS provides wholesale sanitary sewer service to other sewer companies. Charges are based on rates published in Section G of the Fee Schedule of the Policy & Procedure Manual. Rates are intended to cover all costs to MAWSS to collect & treat sewerage from the requesting system.

## SECTION 5

### PRETREATMENT PROGRAM RULES AND REGULATIONS

#### PART I - GENERAL PROVISIONS

##### **5.1 Purpose and Policy**

The Pretreatment Program sets forth uniform requirements for direct and indirect contributors into the wastewater collection and treatment system of the Board of Water and Sewer Commissioners of the City of Mobile (the Board); enables the Board to comply with all applicable State and Federal laws required by the Clean Water Act of 1977 and the General Pretreatment Regulations (40CFR, Part 403).

The Pretreatment Program provides for the regulation of direct and indirect contributors to the Board's wastewater system through the issuance of contracts to certain non-domestic users and through enforcement of general requirements for the other users, authorizes monitoring and enforcement activities, requires user reporting, establishes administrative review procedures, assumes that existing customer's capacity will not be preempted, and provides for the setting of fees for the equitable distribution of costs resulting from the program established herein.

The Pretreatment Program shall apply to persons both within and outside the city limits of the City of Mobile who are, by contract or agreement with the Board, users of the Board's wastewater treatment facilities. Any user that discharges wastewater into the Board's wastewater system, shall comply with the terms and conditions established in the "Pretreatment Program Rules and Regulations", as well as any permits or orders issued hereunder. Except as otherwise provided herein, the Director of the Mobile Area Water & Sewer System or his designees shall administer, implement, and enforce the provisions of the "Pretreatment Program Rules and Regulations". Any powers granted to or duties imposed upon the Director may be delegated by the Director to other Board personnel.

##### **5.2 Objectives**

- 5.2.1 Prevent the introduction of pollutants into the Board's wastewater system that will interfere with the operation of the system or negatively affect the quality of the resulting sludge or its marketability.
- 5.2.2 Prevent the introduction of pollutants into the Board's wastewater system which will pass through the system, inadequately treated, into receiving waters or the atmosphere or otherwise be incompatible with the system.
- 5.2.3 Provide for the equitable distribution of the cost of the Board's wastewater system.
- 5.2.4 Protect, in addition to the general public, the Board's personnel who may come into contact with sewage, sludge and effluent in the course of their employment.

- 5.2.5 Ensure the Board's compliance with its NPDES permit conditions, sludge use and disposal requirements and any other Federal or State laws to which the Board's wastewater system may be subject.
- 5.2.6 Improve the opportunity to recycle and reclaim wastewater and sludge from the system.

### **5.3 Definitions**

Unless the context specifically indicates otherwise, the following terms and phrases, as used in the "Pretreatment Program Rules and Regulations" shall have the meanings hereinafter designated:

**5.3.1 Act or "the Act"** – The Federal Water Pollution Control Act, also known as the Clean Water Act, as amended, 33 U.S.C. 1251 et. seq.

**5.3.2 Approval Authority** – The Approval Authority shall be the Alabama Department of Environmental Management (ADEM), the successor to AWIC.

**5.3.3 Authorized Representative of Industrial User** – An authorized representative of an Industrial User may be:

5.3.3.1 A principal executive officer of at least the level of vice-president, if the Industrial User is a corporation.

5.3.3.2. A general partner or proprietor if the industrial user is a partnership or proprietorship, respectively.

5.3.3.3. A duly authorized representative of the individual designated above if such representative is responsible for the overall operation of the facilities from which the indirect discharge originates.

**5.3.4 Batch Process** – A treatment process in which a tank or reactor is filled, the wastewater (or solution) is treated or a chemical solution is prepared, and the tank is emptied. The tank may then be filled and the process repeated. Batch processes are also used to cleanse, stabilize or condition chemical solutions for use in the industrial manufacturing and treatment processes.

**5.3.5 Biochemical Oxygen Demand** – Shall mean the quantity of oxygen utilized in the biochemical oxidation of organic matter under standard laboratory procedure in five (5) days at 20 degrees centigrade, expressed in parts per million by weight.

**5.3.6 Board** – Shall mean the Board of Water and Sewer Commissioners of the City of Mobile.

**5.3.7 Building Sewer** – Shall mean the extension from the building drain to the sewer lateral at the property line or other lawful place of disposal.

**5.3.8 Categorical Standards** – National Categorical Pretreatment Standards or Pretreatment Standards.

**5.3.9 City** – The City of Mobile or the City Commission or City Council of the City of Mobile.

- 5.3.10 Chemical Oxygen Demand** – Shall mean the quantity of dissolved oxygen required for the chemical oxidation of decomposable matter under aerobic conditions.
- 5.3.11 Composite Sample** – Shall be time-composite sample collected using automatic sampling equipment or a minimum of eight (8) equal volume grab samples collected over equal time intervals for the total period of discharge not to exceed 24 hours.
- 5.3.12 Contractual Arrangement** – Shall mean a contract between a discharger and the Board. A permit issued by the Board to a discharger is also referred to as a contractual arrangement.
- 5.3.13 Cooling Water** - The water discharged from any use such as air conditioning, cooling or refrigeration, or to which the only pollutant added is heat.
- 5.3.14 Constituents** – Shall mean the combination of particles, chemicals or conditions which exist in the industrial waste.
- 5.3.15 Direct Discharge** – The discharge of treated or untreated wastewater directly to the waters of the State of Alabama.
- 5.3.16 Director** – The person designated by the Board to supervise the operation of the publicly owned treatment works and who is charged with certain duties and responsibilities by this article, or his duly authorized representative.
- 5.3.17 Discharge** – The introduction of non-domestic pollutants into the Board’s wastewater collection and treatment system by an industrial user.
- 5.3.18 Effluent** – Shall mean the discharge of flow from a reservoir, basin, treatment process or treatment facility.
- 5.3.19 Effluent Limits** – Pollutant limitations developed by a POTW for each industrial plant discharging to the POTW system. At a minimum, all industrial facilities are required to comply with federal prohibited discharge standards. The industries covered by federal categorical standards must also comply with the appropriate discharge limitations. The POTW may also establish local limits in excess of or in addition to the federal and state standards for some or all of its industrial users.
- 5.3.20 Environmental Protection Agency** – A regulatory agency established by the U.S. Congress to administer the nation’s environmental laws; the U.S. Environmental Protection Agency, or where appropriate the term may also be used as designation for the Administrator or other duly authorized official of said agency.
- 5.3.21 Grab Sample** – A sample that is taken from a waste stream on a one-time basis with no regard to the flow in the waste stream and without consideration of time.
- 5.3.22 Holding Tank Waste** – Any waste from holding tanks such as vessels, chemical toilets, campers, trailers, septic tanks, and vacuum-pump tank trucks.
- 5.3.23 Indirect Discharge** – The discharge or the introduction of non-domestic pollutants from any source regulated under Section 307(b) or (c) of the Act, (33 U.S.C. 1317), into the

Board's wastewater treatment facilities (including holding tank waste discharged into the system).

- 5.3.24 Industrial Plant** – Shall mean any plant producing liquid waste, with or without bearing suspended solids, required to be discharged either with or without pretreatment, into the Board's wastewater system.
- 5.3.25 Industrial Plant Site** - Shall mean a parcel of land occupied by a facility that discharges industrial waste.
- 5.3.26 Industrial Surcharge** – Shall mean an additional service charge assessed against industries in the Board's service system area whose waste characteristics exceed those of normal wastewater, industrial waste or the liquid waste other than domestic sewage resulting from processes or operations employed in industrial establishments. Normal sewage is that waste having BOD of 280 ppm.
- 5.3.27 Industrial Wastewater** – Non-domestic wastewater originating from a non-residential source.
- 5.3.28 Interference** – The inhibition or disruption of the Board's treatment processes or operations that contributes to a violation of any requirement of the Board's Permit. The term includes prevention of sewage sludge use or disposal by the Board in accordance with 405 of the Act, (33 U.S.C. 1345) or any Solid Waste Disposal Act (SWDA), the Clean Air Act, the Toxic Substances Control Act, applicable to the method of disposal or use employed by the Board.
- 5.3.29 National Pollution Discharge Elimination System Permit** – A permit issued pursuant to Section 402 of the Act (33 U.S.C 1342).
- 5.3.30 Non-domestic Pollutant** – Any substance other than human excrement or household gray water.
- 5.3.31 Person or Owner** – Shall mean any individual, partnership, co-partnership, firm, company, corporation, association, joint stock company, trust, estate, governmental entity, or any other legal entity, or their legal representative agents or assigns. The masculine gender shall include the feminine, the singular shall include the plural where indicated by the context.
- 5.3.32 pH** – Shall mean the reciprocal of the log of the weight of hydrogen ions in grams per liter of solution.
- 5.3.33 Pollution** – Shall mean any dredged spoil, solid waste, incinerator residue, sewage, garbage, sewage sludge, munitions, chemical wastes, biological materials, radioactive materials, heat, wrecked or discharged equipment, rock, sand, cellar dirt and industrial, municipal, and agricultural waste discharged into water.
- 5.3.34 Pretreatment or Treatment** – Shall mean the reduction of the amount of pollutants, the elimination of pollutants, or the alteration of the nature of pollutant properties in wastewater to a less harmful state prior to or in lieu of discharging or otherwise introducing such pollutants into the Board's wastewater treatment facilities. Pretreatment shall also mean

that biological, physical or chemical treatment given to waste are those processes utilized for this purpose before discharge into the sanitary sewer system.

- 5.3.35 Pretreatment Specialist** – Board personnel who conduct inspections of industrial pretreatment facilities and food service facilities to ensure protection of the environment and compliance with general and categorical pretreatment regulations.
- 5.3.36 Slug load** – Any pollutant (including BOD) released in a discharge at a flow or concentration that will cause a violation of the specific discharge prohibition.
- 5.3.37 Suspended Solids** – Shall mean solids that either float on the surface of, or that are in suspension in water, sewage or other liquids and which are removable by laboratory filtering.
- 5.3.38 Toxic Pollutant** – Any pollutant or combination of pollutants listed as toxic in regulations promulgated by the Administrator of the Environmental Protection Agency under the provision of CWA 307(a) or other Acts.
- 5.3.39 Treatment plant** – Any device or system used in collection, storage, treatment, recycling and/or reclamation of wastewater.
- 5.3.40 User** – Any person who contributes, causes or permits the contribution of wastewater into the Board’s wastewater treatment facilities also herein referred to as a discharger.
- 5.3.41 Wastewater or Wastes** – Shall mean the used water and water-carried solids from the community that flow into the Board’s wastewater system.
- 5.3.42 Waters of the State** – All streams, lakes, ponds, marshes, watercourses, waterways, wells, springs, reservoir, aquifers, irrigation systems, drainage systems and all other bodies or accumulations of water, surface or underground, natural or artificial, public or private, which are contained within, flow through, or border upon the State or any portion thereof.

#### **5.4 Abbreviations**

The following abbreviations shall have the designated meanings.

- ADEM** - Alabama Department of Environmental Management
- Board** - The Board of Water and Sewer Commissioners of the City of Mobile
- BOD** - Biochemical Oxygen Demand
- CFR** - Code of Federal **COD** - Chemical Oxygen Demand
- CSI** - Compliance Sample
- DMR** - Discharge Report
- EPA** - Environmental Protection Agency

<b>GPD</b> -	Gallons per day
<b>l</b> -	Liter
<b>MGD</b> -	Million gallons per day
<b>mg</b> -	Milligrams
<b>mg/l</b> -	Milligrams per liter
<b>NPDES</b> -	National Pollutant Discharge Elimination System
<b>O/G</b> -	Oil & Grease
<b>POTW</b> -	Publicly Owned Treatment Works
<b>RCRA</b> -	Resource Conservation and Recovery Act
<b>SIC</b> -	Standard Industrial Classification
<b>SID</b> -	State Indirect Discharge Permit
<b>SWDA</b> -	Solid Waste Disposal Act, 42 U.S.C. 6901, et. seq.
<b>TSS</b> -	Total Suspended Solids
<b>USC</b> -	United States Code

## **PART II - REGULATIONS**

### **5.5 REGULATIONS**

#### **5.5.1 General Discharge Prohibitions**

No User shall contribute or cause to be contributed, directly or indirectly, any pollutant or wastewater which will interfere with the operation or performance of the Board's wastewater collection and/or treatment facilities. These general prohibitions apply to all such Users of the Board's wastewater facilities whether or not the User is subject to National Categorical Pretreatment Standards or any other National, State, or local Pretreatment Standards or Requirements. A user may not discharge to the Board's wastewater collection and treatment facilities any of the following:

1. Any liquids, solids, or gases which by reason of their nature or quantity are, or may be, sufficient either alone or by interaction with other substances to cause fire or explosion or be injurious in any other way to the Board's wastewater facilities or to the operation of the Board's wastewater treatment facilities. At no time, shall two successive readings on an explosion hazard meter, at the point of discharge into the system (or at any point in the system) be more than five percent (5%) nor any single reading over ten percent (10%) of the lower explosive limit (LEL) of the meter. Prohibited material include, but are not limited to, gasoline, kerosene, naphtha, benzene, toluene, xylene, ethers, alcohols, ketones,

aldehydes, peroxides, chlorates, perchlorates, bromates, carbides, hydrides, and sulfides and any other substances which the City, the State or EPA has notified the User is a fire hazard or a hazard to the system.

2. Solid or viscous substances which may cause obstruction to the flow in a sewer or other interference with the operation of the wastewater treatment facilities such as, but not limited to: garbage with particles greater than one-half inch (1/2") in any dimension, grease animal guts or tissues, paunch manure, bones, hair, hides or fleshings, entrails, whole blood, feathers, ashes, cinders, sand, spent lime, stone or marble dust, metal, glass, straw, shavings, grass clippings, rags, spent grains, spent hops, waste paper, wood, plastics, gas, tar, asphalt residues from refining, or processing of fuel or lubricating oil, mud, glass grinding or polishing wastes.
3. Any wastewater having a pH less than 6 or higher than 11, unless the Board's wastewater treatment facilities are specifically designed to accommodate such wastewater, or wastewater having any other corrosive property capable of causing damage or hazard to structures, equipment, and/or personnel of the Board's wastewater treatment facilities.
4. Any wastewater containing toxic pollutants in sufficient quantity, either singly or by interaction with the other pollutants, to injure or interfere with any wastewater treatment process, constitutes a hazard to humans or animals, create a toxic effect in the receiving waters of the Board's wastewater treatment facilities, or to exceed the limitation set forth in a Categorical Pretreatment Standard. A toxic pollutant shall include but not be limited to any pollutant identified pursuant to Section 307(a) of the Act.
5. Any noxious or malodorous liquids, gases, or solids which either singly or by interaction with other wastes are sufficient to create public nuisance or hazard to life or are sufficient to prevent entry into the sewers for maintenance and repair.
6. Any substance which may cause the Board's wastewater treatment facilities' effluent or any other product of the Board's wastewater treatment facilities such as residues, sludge, or scum, to be unsuitable for reclamation and reuse or to interfere with the reclamation process. In no case, shall a substance discharged to the Board's wastewater treatment facilities cause the Board's wastewater treatment facilities to be in non-compliance with sludge use or disposal criteria, guidelines or regulations developed under Section 405 of the Act; any criteria, guidelines, or regulations affecting sludge use or disposal developed pursuant to the Solid Waste Disposal Act, the Clean Air Act, the Toxic Substances Control Act, or State Criteria applicable to the sludge management method being used.
7. Any substance which will cause the Board's wastewater treatment facilities to violate its NPDES and/or State Disposal System Permit or the receiving water quality standards.
8. Any wastewater with objectionable color not removed in the treatment process, such as, but not limited to, dye wastes, and vegetable tanning solutions.
9. Any wastewater having a temperature which will inhibit biological activity in the Board's wastewater treatment plant resulting in interference, but in no case wastewater with a temperature at the introduction into the Board's wastewater collection system which exceeds 43 ° C (110° F).



10. Any pollutants, including oxygen demanding pollutants (BOD, etc.) released at a flow rate and/or pollutant concentration which a user knows or has reason to know will cause interference to the Board's wastewater treatment facilities. In no case shall a slug load have a flow rate or contain concentration or qualities of pollutants that exceed for any time period longer than fifteen (15) minutes more than five (5) times the average twenty-four (24) hour concentration, quantities, or flow during normal operation.
11. Any wastewater containing any radioactive wastes or isotopes of such half-life or concentration as may exceed limits established by the Director in compliance with applicable State or Federal regulations.
12. Any wastewater which causes a hazard to human life or creates a public nuisance.
13. Storm water, surface water, ground water, artesian well water, roof runoff, subsurface drainage, condensate, deionized water, cooling water and unpolluted industrial wastewater unless specifically authorized by the Director.

Wastes prohibited by this section shall be processed or stored in such a manner that these wastes could be discharged to the Board's wastewater system. All floor drains located in process or materials storage areas must discharge to the user's pretreatment facility before connecting with the Board's wastewater system.

When the Director determines that a User(s) is contributing to the Board's wastewater treatment facilities, any of the above enumerated substances in such amounts as to interfere with the operation of the Board's wastewater treatment facilities, the Director shall:

- Advise the User(s) of the impact of the contribution on the Board's wastewater treatment facilities
- Develop effluent limitation(s) for such User to correct the interference with the Board's wastewater treatment facilities.

### **5.5.2 Federal Categorical Pretreatment Standards**

Upon the promulgation of the Federal Categorical Pretreatment Standards for a particular industrial sub-category, the Federal Standard, if more stringent than limitations imposed under these Rules and Regulations or sources in that sub-category, shall immediately supersede the limitations imposed under these Rules and Regulations. The Director shall notify all affected Users of the applicable reporting requirements under 40 CFR, Section 403.12.

### **5.5.3 Modification of Federal Categorical Pretreatment Standards**

Where the Board's wastewater treatment system achieves consistent removal of pollutants limited by Federal Pretreatment Standards, the Board may apply to the Approval Authority for modification of specific limits in the Federal Pretreatment Standards. "Consistent Removal" shall mean reduction in the amount of a pollutant or alteration of the nature of the pollutant by the wastewater treatment system to a less toxic or harmless state in the effluent which is achieved by the system 95 percent of samples taken when measured according to the procedures set forth in Section 403.7( c )(2) of (Title 40 of the Code of Federal Regulations, Part 403) – "General

Pretreatment Regulations for Existing and New Sources of Pollution” promulgated pursuant to the Act. The Board may then modify pollutant discharge limits in the Federal Pretreatment Standards if the requirements contained in 40 CFR, Part 403, Section 403.7, are fulfilled and prior approval from the Approval Authority is obtained.

#### **5.5.4 Pretreatment Facilities**

Users shall provide necessary wastewater treatment as required to comply with this Pretreatment Program and shall achieve compliance with all categorical pretreatment standards, local limits, and prohibitions within the time limitations specified by the Director. Any facilities required to pretreat wastewater to a level acceptable to the Board shall be provided, operated, and maintained at the User’s expense. Detailed plans showing the pretreatment facilities and operating procedures shall be submitted to the Director for review.

Grease, oil, and sand interceptors shall be provided when, in the opinion of the Director, they are necessary for the proper handling of wastewater containing excessive amounts of grease, flammable substance, sand, or other harmful substances; except that such interceptors shall not be required for residential users. Such interceptors shall be inspected, cleaned, and repaired regularly, as needed by the owner at this expense.

#### **5.5.5 Specific Pollutant Limitations**

Except as herein otherwise provided, no person shall discharge or cause to be discharged any of the following waters or wastes into any sanitary sewer system of the Board of Water and Sewer Commissioners of the City of Mobile:

1. Any liquid or vapor having a temperature higher than 110 ° F.
2. Any water or waste which may contain more than 100 parts per million by weight of fat, oil, or grease or other substance that will solidify or become viscous at temperatures between 32 ° F and 90 ° F.
3. Any gasoline, benzene, naphtha, fuel oil, or other flammable or explosive liquid, solid or gas.
4. Any water or wastes that contain more than ten parts per million by weight of hydrogen sulfide, sulfur dioxide, and/or nitrous oxide.
5. Any garbage that has not been properly shredded.
6. Any ashes, cinders, sand, mud, straw, shavings, metal, glass, rags, feathers, tar, plastics, wood, paunch manure or other solid or viscous substance capable of causing obstruction to the flow in sewers and other interference with the proper operation of the sewer works.
7. Any waters or wastes having a pH lower than 6.0 or higher than 11.0 or having any other corrosive property capable of causing damage or hazard to the Board’s structures, equipment and personnel.

8. Any waters or wastes containing a toxic or poisonous substance(s) or any other materials in sufficient quantity to injure or interfere with any sewage treatment process, or constitute a hazard to humans or animals, or create any hazard in the receiving waters of the sewage treatment plant, and without proper pretreatment and written approval of the Director.
9. Any waters or wastes containing suspended solids in concentration greater than 250 mg/l and are of such character and quantity that unusual attention or expense is required to handle such materials at the sewage treatment plant.
10. Any noxious or malodorous liquids, gases, or solids which either singly or by interaction with other wastes are sufficient to create public nuisance or hazard to life or are sufficient to prevent entry into the sewers for maintenance and repair.
11. Any waters or wastes containing BOD in concentration greater than 280 mg/l.
12. Any waters or wastes having an objectionable color which is not removable in the existing sewage treatment plant processes.
13. Any unpolluted waters and/or unpolluted wastes.
14. Any long half-life (over 100 days) of toxic radioactive isotopes, without special permit.
15. Any wastewater containing phenols or other taste-producing substances in such concentrations as to produce odor in the effluent as to affect the taste or odor of the receiving waters. Quantities of such substances will be determined by the Director on a case-by-case basis.
16. Any categorical waste in excess of State or Federal effluent guidelines.
17. Any fats or greases including but not limited to petroleum oil, non-biodegradable cutting oil, or products of mineral oil origin, in amounts that will cause interference or pass through.
18. Any material identified as hazardous waste according to 40 CFR Part 261 except as may be specifically authorized by the director.
19. All pollutants listed under Section 5.5 – General Discharge Prohibitions are included in their entirety as part of this section.

The limits fixed herein may be used as a guide in design and plant control, but may be altered by the Director as required or authorized by State or Federal law in the event of a cumulative overload on a particular drainage basin or wastewater treatment plant.

#### **5.5.6 State Requirements**

State requirements and limitations on discharges shall apply in any case where they are more stringent than Federal Requirements and limitations or those in the Pretreatment Program Rules and Regulations.

### **5.5.7 Board's Right of Revision**

The Board reserves the right to establish by resolution more stringent limitations or requirements on discharges to the wastewater disposal system if deemed necessary to comply with the objective presented in Part I Section A of the Pretreatment Program Rules and Regulations.

### **5.5.8 Excessive Discharge**

No User shall ever increase the use of process water or, in any way, attempt to dilute a discharge as a partial or complete substitute for adequate treatment to achieve compliance with the limitations contained in the Federal Categorical Pretreatment Standards, or in any other pollutant-specific limitation developed by the Board or State.

### **5.5.9 Accidental Discharges**

Each User shall provide protection from accidental discharge of prohibited materials or other substances regulated by the Pretreatment Program. Facilities, to prevent accidental discharge of prohibited materials, shall be provided and maintained at the owner's or User's own cost and expense. Detailed plans showing facilities and operating procedures to provide this protection shall be submitted to the Board for review, and shall be approved by the Board before construction of the facility. Review and approval of such plans and operating procedures shall not relieve the User from the responsibility to modify the User's facility as necessary to meet the requirements of the Pretreatment Program Rules and Regulations. In the case of accidental discharge, it is the responsibility of the User to:

1. Immediate Notice – User should immediately telephone and notify the Board of the incident. The notification shall include location of discharge, type of waste, concentration and volume, and corrective actions.
2. Written Notice – Within five (5) days following an accidental discharge: The User shall submit to the Director a detailed written report describing the cause of the discharge and the measures to be taken by the User to prevent similar future occurrences. Such notification shall not relieve the User of any expense, loss, damage, or other liability which may be incurred as a result of damage to the Board's wastewater treatment facilities, fish kills, or any other damage to person or property; nor shall such notification relieve the User of any fines, civil charges, or other liability which may be imposed by this article or other applicable law.
3. Notice to Employees – A notice shall be permanently posted on the User's bulletin Board or other prominent place advising employees whom to call in the event of a dangerous discharge. Employees shall insure that all employees who may cause or suffer such a dangerous discharge to occur are advised of the emergency notification procedure.

## **PART III - FEES**

### **5.6 Purpose**

The fees established in this part of the Pretreatment Rules and Regulations are to provide for the recovery of the costs associated with the implementation and maintenance of the Pretreatment Program from Users of the Board's wastewater disposal system. The applicable charges or fees shall be set forth in the Fee Schedule.

#### **5.6.1 Charges and Fees**

The Board may adopt charges and fees that may include:

1. fees for reimbursement of costs of setting up and operating the Board's Pretreatment Program;
2. fees for monitoring, inspections and surveillance procedures;
3. fees for reviewing accidental discharge procedures and construction;
4. fees for filing appeals;
5. fees for consistent removal (by the Board) of pollutants otherwise subject to Federal Pretreatment Standards;
6. other fees as the Board may deem necessary to carry out the requirements contained herein;
7. charge fees for violation of pretreatment requirements.

These fees relate solely to the matters covered by this Pretreatment Program Rules and Regulations and are separate from all other fees chargeable by the Board.

## **PART IV - PRETREATMENT PROCEDURES (PERMITTING, COMPLIANCE TRACKING, AND ENFORCEMENT)**

The Board's pretreatment program consists of four major elements: the identification and categorization of dischargers and determination of pretreatment requirements; the issuance of permits and contracts; the tracking of dischargers to ensure compliance with permits and contracts; and the enforcement of all pretreatment rules and regulations. The purpose of Part IV is to describe the procedures for meeting the requirements of the four areas listed above. The intent of these procedures is to establish the administrative mechanism to allow the efficient and effective implementation of the Board's Pretreatment Program.

### **5.7 Identification and Categorization of Discharges and Determination of Pretreatment Requirements**

**5.7.1 Identification of Dischargers** - All dischargers of non-domestic waste are subject to pretreatment regulations and must be reviewed to evaluate applicability of pertinent requirements.

**a. Existing Dischargers** – The primary tool for identifying existing dischargers who may be subject to the Board’s pretreatment requirements is a preliminary screening questionnaire and accompanying letter of transmittal. The questionnaire and letter will be sent to any known or suspected discharger who has not been categorized as below. The function of the questionnaire is to obtain sufficient information to determine what further action will be required to categorize the discharger.

Should there be no response from the recipient to the questionnaire, a second questionnaire will be sent with a letter of transmittal detailing the eventual consequence of non-response. Should the second questionnaire elicit no response, the name of the discharger will be referred for follow-up under enforcement procedures.

**b. New Dischargers** – For all new business who apply for services, the Mapping and Connections department sends out fee schedules along with questions on the business, i.e. restaurant, car wash, or other business that may potentially to introduce harmful chemicals into the collections system. Any business that may fall into the harmful chemical category has to be qualified by our consultant and simultaneously reviewed by MAWSS for approval. The pretreatment is alerted of any discharges that may discharge anything other than domestic sewer to determine the nature and volume of discharge. Potential dischargers are sent a questionnaire from pretreatment to determine how the discharger will be categorized (see section c. below). If necessary, a wastewater capacity review is conducted. A record of all businesses contacted and the subsequent responses will be maintained. The Business License office of the City of Mobile will provide each applicant for a business license the questionnaire card provided by Board. The questionnaire card is a numbered, stamped, self-addressed postcard containing questions relating to the use of the Board’s wastewater collection and treatment system on the back. The applicant for the business license shall complete the card and mail it back to the Board.

After the completed card is returned and the responses provided evaluated by the Board, the business will either be placed in the non-significant category or be mailed a more detailed questionnaire.

A record of all businesses contacted and the subsequent responses will be maintained.

**c. Categorization**

Upon receipt of the required information, each business will be placed into one of the following categories for program management. Categorization will be made in as fair and equitable manner as possible. General guidelines for identifying category placement are given below.

- **Category 1** – Those businesses which have no discharge other than normal sanitary wastewater, or whose non-sanitary discharge has no significant effect on the Board’s wastewater collection and treatment system, shall be placed in this category. The businesses so designated will not be tracked by the Board but they

will be maintained in the Board's inventory in case a change in status is required in the future. For those businesses designated Category 1, no contractual arrangement between the Board and discharger will be required.

- **Category 2I** – Businesses with wastewater discharges that do not fall under State or Federal Industrial pretreatment guidelines; and therefore, are not required to obtain a permit from said agencies. However, businesses, with discharges that contain some constituent of concern to the Board, or whose discharge may interfere with the operation and maintenance of the Board's wastewater collection and treatment system will be subject to control by the Board. A contractual arrangement delineating specific requirements for the discharger will be executed between the Board and the discharger for all dischargers designated Category 2I. In addition, the discharger will be subject to the Board's compliance tracking program.
- **Category 2FS** – Businesses that prepare and/or serve food commercially and are not required to obtain a State Indirect Discharge (SID) permit are placed in Category 2FS. A business so categorized will be subject to the Board's compliance tracking program and monitored for oil/grease and any other constituents that, in the Director's judgment, may interfere with the operation and maintenance of the Board's wastewater collection and treatment system. A contractual arrangement delineating specific requirements for the discharger will be executed between the Board and the discharger so designated.
- **Category 3** – Businesses that are subject to State and Federal Industrial Pretreatment rules and regulations and are required to obtain a SID permit will be placed in this category. Generally, in accordance with state requirements, a business discharging a wastewater with one or more of the following characteristics will be placed in Category 3:
  - the discharge of more than 25,000 GPD of process wastewater
  - b. the discharge in significant quantities of one or more of the EPA designated categorical wastes
  - c. the discharge in significant quantities of a prohibited or potentially prohibited waste

**Businesses placed in this category will be permitted by the State, and will be required to execute a contractual arrangement with the Board for the purpose of providing the Board a means of regulating the discharge, and will be subject to the Board's compliance tracking program.**

d. Monitoring Facilities

The Board shall require the Category 2I or 3 User to provide and operate, at the user's own expense, monitoring facilities to allow inspection, sampling, and flow measurement of the building sewer and/or internal drainage system. The monitoring facility shall normally be situated in the User's premises, but the Board may, when such a location would be impractical or cause undue hardship on the user, allow the facility to be

constructed in the public street or sidewalk area with the required, appropriate permission from the City and located so that it will not be obstructed by landscaping or parked vehicles. There shall be ample room in or near such sampling manhole or facility to allow accurate sampling and preparation of samples for analysis. The facility, sampling, and measuring equipment shall be maintained at all times in a safe and proper operating condition at the expense of the user. The Board shall provide the monitoring facility for a category 2FS discharger at its own expense. The monitoring facility shall normally be situated in the right-of-way or easement area.

**e. Inspection and Sampling**

The Board shall inspect the facilities of any User to ascertain whether the User is complying with all requirements and the purpose of the Pretreatment Program is being met. Persons or occupants of premises where wastewater is created or discharged shall allow the Board or its representative ready access at all reasonable times to all parts of the premises for the purposes of inspection, sampling, records examination or in the performance of any of their duties. The Board and the Approval Authority shall have the right to set up on the User's property such devices as are necessary to conduct sampling inspection, compliance monitoring and/or metering operations. Where a User has security measures in force which would require proper identification and clearance before entry into their premises, the User shall make necessary arrangements with their security guards so that upon presentation of suitable identification, personnel from the Board, Approval Authority and EPA will be permitted to enter, without delay, for the purposes of performing their specific responsibilities.

**f. Determination of Pretreatment Requirements**

After the User is placed in one of the categories previously described, requirements for Category 2I and 3 dischargers must be determined. The Board will make Category 2I requirements based on available information and Category 3 requirements in coordination with ADEM. Effluent limits for priority/categorical pollutants will be in accordance with those promulgated by EPA and ADEM; unless more stringent limits are necessary to protect the Board's wastewater collection and treatment system.

**5.8 Appeal Procedures for any Pretreatment Requirement**

Decisions concerning pretreatment requirements for dischargers within the Board's purview will be made by the Director of the system. Should the discharger object to the Director's decision, the procedures listed below are applicable:

1. Written notice of the objection should be made to the Director of the Mobile Area Water and Sewer System within thirty (30) calendar days of notification of the requirement. The Director will reply to the objection within 20 working days. Decisions by the Director may be appealed to the Board, or to a committee that the Board for the purpose of hearing such appeals may establish. Decisions by the Board are final except in cases where ADEM must also concur.
2. Any written appeal submitted and received by the Board, which is not addressed within 20 working days of receipt, or set for hearing, is considered granted to the discharger.



3. The thirty-day period within which the discharger can appeal may be waived by the Director if extenuating circumstances so justify.
4. The appellant will be given the time, date and place of the hearing, and may present said objection in his behalf at said hearing.
5. If an appealing discharger is a category 3 discharger (SID permit required) the final appeal concerning issuance of the SID permit requirement(s) must be to the State agency, ADEM. The Board's recommendations must accompany the discharger's appeal to the State.
6. The Board may conduct the hearing and take the evidence, or may designate any of its members or any officer or employee to:
  - a. issue in the name of the Board notices of hearings requesting the attendance and testimony of witnesses and the production of evidence relevant to any matter involved in such hearings.
  - b. take the evidence;
  - c. transmit a report of the evidence and hearing, including transcripts and other evidence, together with recommendations to the Board for action thereof.
7. At any hearing held pursuant to the Pretreatment Program Rules and Regulations, testimony taken may be under oath and recorded stenographically. The transcript, so recorded, will be made available to any member of the public or any party to the hearing upon payment of the usual charges thereof.
8. After the Board has reviewed the evidence, it may issue an order to the User responsible for the discharge directing that, following a specified time period, the sewer service be discontinued unless adequate devices or other related appurtenances are installed on existing treatment facilities, and such devices or other related appurtenances are properly operated and maintained. Further orders and directives as are necessary and appropriate may be issued.

## **5.9 Modification of Program Requirements for Dischargers**

Periodically, changes in pretreatment requirements of existing dischargers may be appropriate. When such changes are deemed necessary, the procedures listed below are applicable:

1. The dischargers will be notified in writing of the proposed change and of the basis for the change.
2. Included in the notice of change will be any draft permit or contractual requirements, if appropriate.
3. The proposed change in discharger requirements will be effective thirty (30) days after notice. Should a discharger object to the change, such objection must be registered with the Board within thirty (30) days of receipt of the notice of proposed change.
4. The filing of a request by the User for a permit modification does not stay any condition of its existing contractual agreement.

## 5.10 Permits and Contracts

The basis for regulating discharges to the Board's wastewater collection and treatment system will be through SID permits and through contracts between the discharger and the Board. SID permits will be issued and enforced by ADEM in coordination with the Board but are not directly controlled by the Board. The Board will execute contracts with Category 2I, 2FS and 3 dischargers. These contracts will specifically identify all pretreatment requirements to be enforced by the Board that the discharger must meet and will provide the Board that authority required by Federal pretreatment regulations but not granted the Board under enabling statute. Dischargers may be subject to other State and Federal pretreatment requirements not included in the Board's contract.

Should a user be required to construct a pretreatment facility, such a requirement and a schedule for completion of such facility will be included as an enforceable portion of the user's contract.

### 1. Contract Application

Users required to obtain a SID permit shall complete and file with the Board, an application in the form prescribed by the Board. Proposed new users shall apply at least 90 days prior to connecting to or contributing to the Board's wastewater collection and treatment facilities. In support of the application, the user shall submit, in units and terms appropriate for evaluation, all information supplied to the State.

### 2. Contract Conditions

Pretreatment Program Wastewater Discharge Contracts (Contract) shall be expressly subject to all provisions of the "Pretreatment Program Rules and Regulations" and all other applicable regulations, users' charges and fees established by the Board. Contracts may contain the following:

- a. the unit charge or schedule of user charges and fees for the wastewater to be discharged to a community sewer;
- b. limits on the average and maximum wastewater constituents and characteristics;
- c. limits on average and maximum rate and time of discharge or requirements for flow regulations and equalization;
- d. requirements for installation and maintenance of inspection and sampling facilities;
- e. specifications for monitoring programs which may include sampling locations, frequency of sampling, number, types and standards for tests and reporting schedule;
- f. compliance schedule;
- g. requirements for submission of technical reports or discharge reports;
- h. requirements for maintaining and retaining plant records relating to wastewater discharge as specified by the Board, and affording Board access thereto;

- i. requirements for notification of the Board of any new introduction of wastewater constituents or any substantial change in the volume or character of the wastewater constituents being introduced into the wastewater treatment system;
- j. requirements for notification of slug discharges;
- k. other conditions as deemed appropriate by the Board to ensure compliance with these Regulations.

3. Contract Duration

Contracts shall be issued for specified time period, not to exceed five (5) years. A contract may be issued for a period of less than a year or may state the specific date of expiration. A minimum of 180 days prior to the expiration of the user's existing contract, the user shall apply for renewal of the contract. The terms and conditions of the contract may be subject to modification by the Board during the term of the contract as limitations or requirements as identified in PART 2 are modified or other just cause exists. The user shall be informed of any proposed changes in his contract at least 30 days prior to the effective date of the change. Any changes or new conditions in the contract shall include a time schedule for compliance.

4. Contract Transfer

Pretreatment Program Wastewater Discharge Contracts are issued to a specific user for a specific operation. A wastewater discharge contract shall not be reassigned or transferred or sold to a new owner, new user, different premises, or a new or changed operation without the approval of the Board. Any succeeding owner or user shall also comply with the terms and conditions of the existing contract.

5. Confidential Information

- a. Information and data on a user obtained from reports, questionnaires, permit applications, permits and monitoring programs and from inspections shall be available to the public or other governmental agency without restriction unless the user specifically requests and is able to demonstrate to the satisfaction of the Board that the release of such information would divulge information, processes or methods of production entitled to protection as trade secrets of the user.
- b. When so requested by the person furnishing a report, the portions of a report which might disclose trade secrets or secret processes shall not be made available for inspection by the public but shall be made available upon written request to governmental agencies for uses related to the Pretreatment Program Rules and Regulations, the NPDES, the SID and/or Pretreatment Programs; provided, however, that such portions of a report shall be available for use by the State or any state agency in judicial review or enforcement proceedings involving the person furnishing the report. Wastewater constituents and characteristics will not be recognized as confidential information.

The Board shall, not transmit to any governmental agency or to the general public information accepted by the Board as confidential, until and unless a ten-day notification is given to the User.

## **5.11 Compliance Tracking**

The purpose of the compliance tracking program is to insure all Category 2I, 2FS and 3 dischargers are meeting the terms of their contracts. There are four major components of the compliance tracking program.

### **1. Self-Monitoring Reports**

- a. Category 3 dischargers are required to submit a self-monitoring (DMR) report, either monthly or quarterly, to ADEM as designated in their SID permit. A copy of this report is to be submitted to the Board so that it is received no later than the 28<sup>th</sup> day following the monitoring period covered. Failure to submit such report will be a breach of the executed contract and could result in enforcement action.
- b. Category 2I dischargers are required to submit a monthly, self-monitoring report, containing those parameters designated in their contract with the Board, so that it is received no later than the 28<sup>th</sup> day following the monitoring period covered. Failure to submit such report will be a breach of the executed contract and could result in enforcement action.
- c. Category 2FS dischargers are not required to submit a monthly, self-monitoring report. The Board does all official monitoring.

### **2. Compliance Evaluation Inspections**

The purpose of compliance evaluation inspections (CEI) is to insure the proper operations of any pretreatment facilities specified in contracts with Category 2I, Category 2FS, and Category 3 dischargers. These inspections are a “walk-through” type and do not involve effluent sampling. These inspections should confirm that all required facilities are in place and being properly operated. A CEI may be done concurrently with the compliance sampling inspection (CSI) described below. All Category 3, 2I and 2FS facilities will receive a CEI annually.

### **3. Compliance Sampling Inspection**

The purpose of the compliance sampling inspection (CSI) is to ensure that those effluent limits specified in a discharger’s contract are being achieved.

- a. During a CSI for Category 3 or 2I dischargers, samples will be taken from the discharger’s effluent each month and analyzed for those parameters contained in their Pretreatment Program Wastewater Discharge Contract. Generally, there will be three samples taken each month unless, in the Director’s judgment, circumstances dictate the necessity for the collection of more or fewer samples during a particular period of time.

- b. During a CSI for category 2FS dischargers, a grab sample will be taken from the discharger’s effluent twice each month and analyzed for those parameters contained in their Pretreatment Program Wastewater Discharge Contract.
- c. Upon being placed on the compliance tracking program, dischargers must prove. compliance by the following timeline.
  - I. The discharger will be sampled monthly for 3 consecutive months.
  - II. If there has been no significant non-compliance of a discharge parameter during quarterly sampling, the sampling schedule will be reduced to 4 consecutive quarters.
  - III. If there has been no significant non-compliance of a discharge parameter during quarterly sampling, the sampling schedule will be reduced to bi-annually for one year.
  - IV. If there has been no significant non-compliance of a discharge parameter after bi-annual sampling, the discharger will be placed on an annual sampling schedule

**If at any time, sample results indicate a significant non-compliance situation, the discharger will be placed on a monthly CSI schedule and shall be required to prove compliance through the procedure described above. Results of self-monitoring may also be used in determining compliance.**

Any discharger that meets one or more of the following criteria shall be considered in significant non-compliance:

- Chronic violations of wastewater discharge limits, defined here as those in which 66% or more of all the measurements taken during a 6-month period exceed (by any magnitude) the daily maximum limit or the average limit for the same parameter.
- Technical review criteria (TRC) violations, defined here as those in which 33% or more of all the measurements for each pollutant parameter taken during a 6-month period equal or exceed the product of the daily maximum limit or the average limit multiplied by the applicable TRC (TRC=1.4 for fats, oil and grease, and 1.2 for all other parameters except pH).
- Any other effluent violation of a pretreatment effluent limit (daily maximum or longer-term average) that the control authority determines has caused alone or in combination with other discharges, interference or pass-through (including endangering the health of POTW personnel or the general public).

4. Inspection Summary Reports

Reports will be maintained of all inspection results. The reports to be generated and their disposition are shown below:

Report Title	Contents	Disposition	
CSI	Results of Compliance Sampling Inspection	Discharger PT File	ADEM
CEI	Results of Compliance Evaluation Inspection	Discharger PT File	ADEM

<b>Exception</b>	<b>Monthly List of non-compliant discharger</b>	<b>Wastewater Services Engineer</b>
<b>Annual</b>	<b>Summary of discharger who had significant violations during the calendar year</b>	<b>Submitted to ADEM for handling in accordance with Federal Regulations</b>

**PART V - ENFORCEMENT ACTIONS**

**5.12 Actions Available for Enforcement**

<b>Action</b>	<b>Application</b>	<b>Description</b>	<b>Industrial User Response</b>	<b>Charge</b>
<b>Notice of non-compliance</b>	<b>Non-significant instance of non-compliance</b>	<b>Letter advising industrial user of instance of non-compliance</b>	<b>None</b>	<b>None</b>
<b>Notice of violation</b>	<b>Significant instance of non-compliance</b>	<b>Letter advising industrial user of instance of non-compliance</b>	<b>Investigation, report, and statement of corrective action</b>	<b>\$100 - \$10,000 per occurrence, to be assessed if industrial user fails to comply with subsequent Board order</b>
<b>Notice of Violation</b>	<b>Significant instances of non-compliance or any discharge which threatens POTW and/or general public</b>	<b>Cease and desist order requiring compliance within 90 days</b>	<b>Formal compliance plan and schedule, interim and final compliance progress reports</b>	<b>\$1000 - \$10,000 per occurrence, to be assessed if industrial user fails to comply with subsequent Board order</b>

**5.13 Harmful Contributions**

5.13.1 The Board may suspend the wastewater treatment service and/or a Pretreatment Program Wastewater Discharge contract when such suspension is necessary, in the opinion of the Board, in order to stop an actual or threatened discharge which presents or may present an imminent or substantial endangerment to the health or welfare of the persons or the environment, causes interference to the Board's Wastewater Collection and Treatment System or causes the Board to violate any conditions of its NPDES Permit.

5.13.2 Any person notified of a suspension of the wastewater treatment service and/or their Pretreatment Program Wastewater Discharge contract shall immediately stop or eliminate the contribution. In the event of the failure of the person to comply voluntarily with the suspension order, the Board shall take such steps as deemed necessary including immediate severance of the sewage connection, to prevent or minimize damage to the Board's wastewater collection and treatment system or endangerment to any individuals. The Board shall reinstate the contract and/or wastewater treatment service upon statement submitted by the user describing the causes of the harmful contribution and the measures taken to prevent any future

occurrence shall be submitted to the Board within 15 days of the date of the occurrence.

#### **5.14 Special Charges and Contracts**

All charges for collection, receiving, transporting and treating industrial waste and industrial wastewaters will be subject to negotiation. The amount charged will include all expenses incurred by the Board in handling and treating such waste and will include any cost of chlorinating the same when mixed with the sanitary sewage. All of such services must be approved and the terms and conditions fixed under the provision of written contracts.

All industrial wastes or industrial wastewaters discharged into the system under agreement with the Board where BOD does not exceed 280 ppm, where fats do not exceed 100 ppm, and where the TSS does not exceed 250 ppm shall be handled by the Board for the rates adopted and published by the Board.

However, all industrial wastes or industrial wastewaters discharged into the system which exceed the limits above shall pay additional charges at the rate per pound as stated in the "Mobile Area Water and Sewer System Policy and Procedures Handbook." The Board will not consider levels of BOD and TSS in excess of the above limits as significant non-compliance.

In the event excess fats continue to be discharged after warning from the Board, the Board may elect to discontinue the service on twenty-four hours' notice and such election shall not prejudice the claim of the Board for any sums due hereunder. Notice of such election shall be given by certified mail.

All industrial waste, before being discharged into the sewer system of the Board, shall be metered and no waste shall be discharged until so metered. Cost of the meter shall be borne by user. Appropriate devices or access areas shall be installed and maintained for the purpose of sampling such waste and the Board shall have free and continued access over the property of the user for the purpose of sampling the waste.

The Board may take such samples at any time or any place as determined by the Board.

Any industry that wishes to discharge a waste containing any one or combinations of waste as outlined in Part II Section 5.5.1 above shall negotiate the charges with the Board on all other types of wastes not specifically charged by the "Pretreatment Program Rules and Regulations", and cannot discharge any waste into the system unless and until a written agreement is negotiated and entered into.

The Board reserves the right to enter into special contracts with industrial customers for the collection, treatment and disposal of industrial or sanitary sewage or waste and to enter into contracts for the construction and use of special treatment plants under the terms and conditions for the use thereof, and the provisions of this section may be altered, changed, amended or extended under the terms and conditions of such contracts.

### **5.15 Termination of Contract**

Any User who violates the following conditions of the “Pretreatment Program Rules and Regulations”, or applicable state and federal regulations, is subject to having its contract terminated in accordance with the procedures of Part V of the “Pretreatment Program Rules and Regulations”.

1. Failure of a user to factually report the wastewater constituents and characteristics of his discharge
2. Failure of the user to report significant changes in operations, or wastewater constituents and characteristics
3. Refusal of reasonable access to the user’s premises for the purpose of inspection or monitoring
4. Violation of conditions of the contract

### **5.16 Termination of Service**

The Board may terminate water and wastewater disposal service and disconnect a pretreatment customer from the system when:

1. A government agency informs the Board that the effluent from the wastewater treatment plant is no longer of quality permitted for discharge to a watercourse, and it is found that the customer is delivering wastewater to the Board’s system that cannot be sufficiently treated or requires treatment that is not provided by the Board as normal domestic treatment.
2. The customer:
  - a. discharges industrial waste or wastewater that is in violation of the Pretreatment Program Wastewater Discharge contract with the Board;
  - b. discharges water or wastes having a deleterious effect upon the Board’s sewer system;
  - c. discharges wastewater at an uncontrolled, variable rate in sufficient quantity to cause an imbalance in the wastewater treatment system;
  - d. repeats a discharge of prohibited wastes to the Board’s sewer;
  - e. fails to pay monthly bills for water and sewer service when due;
  - f. fails to pay all Pretreatment Program charges when due.

The Board shall not be held responsible in any way for any damages or inconveniences experienced by the user as a result of termination of service.



## **5.17 Legal Action**

If any person discharges sewage, industrial wastes or other wastes into the Board's wastewater disposal system contrary to the provisions of the "Pretreatment Program Rules and Regulations" Federal or State Pretreatment Requirements, or any order of the Board, the Board's attorney may commence an action for appropriate legal and/or equitable relief in the Circuit Court of this county, the United States District Court or other proper court. In the event that the Board is required to take legal action in the Board's behalf or to defend the Board, for any matter arising out of the improper discharge of wastewater into the Board's treatment and/or collection facility, for violation of any of these Pretreatment Rules and Regulations, for breach of contract or any other matter arising under the contract between the User and the Board, then the User shall pay all the Board's attorneys' fees, expenses and costs.

### **PART VI - INDEMNIFICATION**

In any and all instances where the Board has reasonable cause to believe that any of the rules, regulations, or provisions set forth in "Pretreatment Program Rules and Regulations" or that have otherwise been adopted by the Board have been, may be, or are being violated by any user discharging waste into the Board wastewater collection and treatment system, the Board may require such person to give bond or enter into an indemnity agreement in a form acceptable to the Board with sufficient surety to protect, indemnify, hold harmless and defend the Board from any loss, damage, or expense that may suffer or incur as a result of non-compliance or violation by such user; and, in the event of the failure to do so after ten (10) days' notice by registered U. S. Mail that the same will be required, the use of the Board's wastewater collection and treatment system by such user shall be denied or discontinued.

### **PART VII - SEVERABILITY**

If any provision, paragraph, word, section or article of the "Pretreatment Program Rules and Regulations" is invalidated by any court of competent jurisdiction, the remaining provision, paragraphs, words, sections, and chapters shall not be affected and shall continue in full force and effect.

### **PART VIII - CONFLICT**

All other resolutions and parts of other resolutions inconsistent or in conflict with any part of the "Pretreatment Program Rules and Regulations" are hereby repealed to the extent of such inconsistency or conflict.

### **PART IX - EFFECTIVE DATE**

The "Pretreatment Program Rules and Regulations" shall be in full force and effect from and after its adoption, approval and publication, as provided by law.

## **PART X - SPECIAL AGREEMENTS**

No statement contained in the "Pretreatment Program Rules and Regulations" shall be construed as preventing any special agreement or arrangement between the Board and any industrial concern by the Board for treatment, subject to payment therefore, by the industrial concern.

## Section 6

### Cross-Connection and Backflow Prevention Program

#### 6.01 Intent of Policy

The Board of Water and Sewer Commissioners of the City of Mobile (also known as the Mobile Area Water and Sewer System [MAWSS]) is responsible for maintaining a cross-connection control program that protects public potable water supply against actual or potential contamination from cross-connection, backpressure, or back-siphonage. As a result, MAWSS has developed a Cross-Connection and Backflow Prevention Program (the “Program”) in compliance with the latest edition of the International Plumbing Code, International Fire Code, American Water Works Association (AWWA) Manual of Water Supply Practices M14, and Alabama Department of Environmental Management Regulation (ADEM) Admin., Code R. 335-7-9-03. The Program requires that all new and certain existing water service connections contain a backflow prevention device/assembly.

This policy relies on three backflow prevention methodologies: isolation, elimination, and program maintenance. **Isolating** the customer’s internal distribution system(s) or the customer’s private water system(s) from potential backflow or back-siphonage into the public water system helps maintain the safety and quality of the public potable water supply. Customers are responsible for ensuring that no contaminants or pollutants from their private plumbing enter into the public water system. The policy promotes **eliminating** cross-connections at new and existing service connections, actual or potential, between MAWSS’ public potable water system and the customer’s service connection. The policy is not intended to protect against cross-connections within the plumbing system owned by the customer. The policy also provides for the **maintenance** of a continuing program of cross-connection control with a goal to systematically and effectively prevent the contamination or pollution of MAWSS’ potable water system, and provides for discontinuance of service for violation of the policy.

Note that MAWSS will not perform cross-connection surveys on the customer’s property so this policy does not intend to protect the property occupants from internal cross-connections. Customers may elect to procure the services of a licensed plumber to perform surveys of their internal system if further protection is desired. However, MAWSS may perform surveys to determine the degree of hazard for the purpose of identifying the backflow prevention assemblies/ devices as required to protect the public water supply.

#### 6.02 Definitions

ADEM: Alabama Department of Environmental Management; <http://www.adem.state.al.us>

Auxiliary Water Supply: Any water source on or available to the premises other than that supplied by MAWSS. These auxiliary sources of water include, but are not limited to, other public water system sources or other unapproved onsite source(s) which are not under the control of MAWSS’s system, such as a well, lake, spring, river, stream, harbor, etc. Auxiliary water sources may also include graywater, rain or storm water, reclaimed waters, or recycled waters.

Backflow Preventer: An assembly, device, or method that prevents backflow.

Backflow Prevention Assembly: Mechanical devices that are in-line performance testable and repairable with two properly located approved shutoff valves and properly located test cocks.

Backflow Prevention Device: An item that prohibits the backflow of nonpotable water into potable water supply systems. It is not performance-testable.

Backflow: The reversal of the normal flow of water caused by either back-pressure or back-siphonage.

Back-pressure: A type of backflow where the pressure is higher on the customer's premises than the incoming supply pressure from the water utility.

Back-siphonage: A type of backflow where the upstream pressure in the utility's piping system is reduced to a subatmospheric pressure. This can be caused by a water main break or flows in the water main to fight fires.

Board: The Board of Water and Sewer Commissioners of the City of Mobile.

Certified Tester and Installer: A person who is certified by an AWWA or similar program (see *Section 6.15*) and approved by MAWSS to install and field-test backflow prevention assemblies.

Cross-Connection: An actual connection or a potential connection between any part of a potable water system and any other environment that would allow substances to enter the potable water system. Those substances could include gases, liquids, or solids, such as chemicals, water products, steam, water from other sources (potable or nonpotable), or any matter that may change the quality, color or odor of the water. Bypass arrangements, jumper connections, removable sections, swivel or change-over assemblies, or any other temporary or permanent connecting arrangement through which backflow may occur are considered to be cross-connections.

Customer: A person who utilizes water from a public water system.

Degree of Hazard: The results of an assessment or evaluation of a customer's use of water in regard to the potential risk to health or an adverse effect on a potable water system.

Double Check Valve Assembly: A backflow prevention assembly consisting of two internally loaded independently operating check valves, located between two tightly closing resilient-seated shutoff valves with four properly placed resilient-seated test cocks. This assembly shall only be used to protect against a non-health hazard (that is, a pollutant).

Dual Check Valve (Residential): A backflow prevention device consisting of two check valves. This device is suitable for low hazard cross-connections and both back-pressure and back-siphonage conditions. This device is not testable.

Existing: Service connections that were already installed at the time the policy was adopted.

Health Hazard: A cross-connection or potential cross-connection involving any substance, herein referred to as contaminants, that could, if introduced into the potable water supply, cause death or illness, spread disease, or have a high probability of causing such effects. These substances are listed in the Environmental Protection Agency (EPA) National Primary Drinking Water Standards.

IBC: International Building Code, latest edition

IFC: International Fire Code, latest edition

IPC: International Plumbing Code, latest edition

Irrigation Customer (for the purposes of this document): An existing residential or non-residential customer that installs a separate meter for an onsite irrigation system.

Latest Edition: Latest approved and adopted edition of the referenced code or manual.

MAWSS: The Mobile Area Water and Sewer System or Board of Water and Sewer Commissioners of the City of Mobile.

Non-Health Hazard: Any substance that generally would not be a health hazard but would constitute a nuisance or be aesthetically objectionable if introduced into the potable water supply, herein referred to as those substances listed in the EPA National Secondary Drinking Water Standards.

Non-Potable Water: Water that is not safe for human consumption or is of questionable safety.

Non-Residential Customer (for the purposes of this document): Multifamily dwellings served by one master meter; retail, offices, hotels, motels, shopping centers, medical facilities, and other commercial buildings (commercial); and manufacturing or process facilities, which are engaged in producing a product (industrial).

Pollution Hazard: See non-health hazard.

Potable Water: Water that is safe for human consumption as described by the public health authority having jurisdiction.

Program: The Program developed and adopted by MAWSS and implemented in accordance with the policy described herein.

Reduced Pressure Principle Assembly: A backflow prevention assembly consisting of a mechanical, independently acting, hydraulically dependent relief valve, located between two independently operating, internally loaded check valves that are located between two tightly closing resilient-seated shutoff valves with four properly placed resilient-seated test cocks. This assembly is suitable for direct high hazard cross-connections.

Residential Customer (for the purposes of this document only): Single-family detached dwellings and multifamily complexes served by individual meters.

Thermal Expansion: A physical property related to a water volume increase inside the pipe or water heater when water is heated. Moreover, back-pressure backflow may result if the pressure increases, caused by water expansion, is not dissipated.

Used Water: Any water supplied by MAWSS' water system to a consumer's water system after it has passed through the point of delivery and is no longer under the sanitary control of the water supplier.

Water Service Connection: The connection between MAWSS' public water distribution system main and a user's domestic water system.

Water Supplier: The owner or operator of a public water system (for example, MAWSS).

### **6.03 Statement of Policy**

MAWSS is responsible for evaluating and monitoring hazards inherent in supplying potable water to customers. The customer is responsible for preventing any contaminants from flowing into MAWSS's system from their plumbing system. When a hazard or potential hazard is identified, the customer is responsible for installation, testing, and certification of the approved backflow prevention device(s)/assembly(ies). To enforce this policy and to protect the public water supply from pollution or contamination resulting from a cross-connection, the following rules apply:

1. No person shall make or allow a connection to exist at any premises between pipes or conduits carrying potable water supplied by MAWSS and any pipes, conduits, or fixtures containing or carrying liquids, gas, or other substances from any other source.
2. No water service piping by any private water supply system or industrial process or water piping system owned by any person shall be connected to the public potable water system owned and operated by MAWSS.
3. The customer is responsible for ensuring that no contaminants or pollutants flow from his/her private plumbing into the public water system.
4. Non-residential customers shall notify MAWSS if use of the water changes at the premises.
5. No water service connection will be made by MAWSS until an approved backflow prevention assembly is installed and tested.
6. Any non-residential or new residential customer of MAWSS who has the potential for a cross-connection shall, at his/her own expense, install, operate, test, and maintain approved backflow prevention assembly as directed by MAWSS. Backflow prevention assembly shall be tested for effectiveness and reliability upon installation in accordance with the Program, with the customer submitting a Backflow Assembly Test Report to MAWSS for each backflow prevention assembly on the customer's premises.
7. MAWSS shall install backflow prevention assemblies for customers with meters less than or equal to 1 inch in diameter and the customer's water is classified as a non-health hazard.
8. The customer shall procure the services of a certified installer to install a backflow prevention assembly on water service with meters greater than 1 inch in diameter, as well as on service with meters less than or equal to 1 inch in diameter and the water use is classified as a health hazard. The customer shall also procure the services of a certified tester to test the assembly after the initial installation and at the frequency specified in this document.

9. Water service to any premises shall be disconnected by MAWSS if a backflow prevention assembly required by MAWSS is not installed, tested, and maintained; if it is found that a backflow prevention assembly has been removed or by-passed; if unprotected cross-connections exist on the premises; or there is inadequate backflow prevention at the service connection. Water service will not be restored until such conditions or defects are corrected and evidence thereof is provided to MAWSS by the customer.

#### **6.04 New Service Connections**

##### **A. General**

New service connections will be evaluated by MAWSS to determine the degree of hazard and the type of backflow prevention device/assembly required to protect the potable water system from actual or potential contamination or pollution. Criteria used for evaluation of residential, non-residential, and irrigation service connections are outlined in Section 6.10, Backflow Prevention Selection Criteria and Section 6.11, Facilities Requiring Backflow Prevention Assemblies. Customer shall notify MAWSS by email if the use of the water by the customer changes, as it could require a different type of backflow prevention device.

##### **B. Residential**

MAWSS shall install dual check valves for new residential service connections for meters on line sizes less than or equal to 1 inch in diameter. MAWSS shall also install dual check valves when water meters and service lines less than or equal to 1 inch in diameter are replaced for existing customers that do not have a suitable backflow prevention device already installed, per ADEM Code R. 335-7-9-03. Residential customers will not be required to test the dual check valve device.

##### **C. Non-Residential**

Non-residential customers with water meters on line sizes greater than 1 inch in diameter and/or the water use is classified as a health hazard shall install the backflow prevention assembly, as specified herein, and have the assembly tested by a certified tester at the customer's expense. For line sizes equal to or less than 1 inch in diameter and the water use is considered a non-health hazard, MAWSS shall install and test the device.

##### **D. Irrigation**

For meters on line sizes greater than 1 inch in diameter and/or water in the customer's irrigation system is classified as a health hazard, new service connections for dedicated irrigation systems shall have backflow prevention assemblies installed and tested at the customer's expense. Typically, a double check valve assembly will be required for irrigation, but an assembly providing greater protection, such as a reduced pressure backflow assembly, may be required depending on internal connections to the irrigation system (for example, chemical feed system). See Section 6.10, Backflow Prevention Selection Criteria.

For meters on line sizes less than or equal to 1 inch in diameter and the water use is classified as non-hazard, MAWSS shall install a double check valve assembly for new service, but testing will be performed by a certified tester at the customer's

expense in accordance with Section 6.15, Testing and Repairs of Backflow Prevention Assemblies.

## **6.05 Existing Service Connections**

### **A. General**

Existing service connections will be evaluated by MAWSS to determine the degree of hazard and the type of backflow prevention device/assembly required to protect the potable water system from actual or potential contamination or pollution. Criteria used for evaluation of residential, non-residential, and irrigation service connections are outlined in Section 6.10, Backflow Prevention Selection Criteria and Section 6.11, Facilities Requiring Backflow Prevention Assemblies. Customer shall notify MAWSS if the use of the water by the customer changes, as it could require a different type of backflow prevention device.

### **B. Residential**

An approved backflow prevention device, dual check valve for residential customers, shall be installed on each customer water service connection that is replaced, repaired, or relocated. If the existing residential customer water meter or service line is replaced, repaired, or relocated, MAWSS will install the dual check valve backflow prevention device. Residential customers will not be required to test the dual check valve device.

### **C. Non-Residential**

MAWSS will send a Cross Connection Survey to those existing non-residential customers without an existing backflow prevention assembly and/or when the potential sources of backflow or the degree of hazards are unknown (see Section 6.17, Reports and Records and Appendix A). MAWSS inspectors will meet with the customer, if necessary, to assist with filling out the survey. MAWSS will evaluate the survey responses to identify actual or potential cross-connections at the service connection. If actual or potential cross-connections are identified, the MAWSS-approved backflow prevention assembly shall be installed and tested by the customer.

Refer to Section 6.15, Testing and Repairs of Backflow Prevention Assemblies, for additional requirements.

### **D. Irrigation**

Double check valves previously installed by MAWSS on existing irrigation meters can remain in service. All existing backflow prevention assemblies must be tested annually by a MAWSS-approved and certified tester, hired at the customer's expense. See Section 6.15, Testing and Repairs of Backflow Prevention Assemblies.

## **6.06 Responsibilities of MAWSS, Customer, and tester**

### **A. MAWSS**

MAWSS shall be responsible for developing, implementing and enforcing a cross-connection and backflow prevention policy to reasonably protect the public potable water distribution system from contaminants or pollutants back-flowing from



customers through their public potable water service connection. MAWSS' responsibility begins at the water supply source and ends at the service connection to the customer's water system. MAWSS is not responsible for losses or damages that the customer may incur because of the installation of a backflow prevention device/assembly. MAWSS is also not responsible for preventing cross-connections within the customer's internal plumbing system.

If MAWSS decides that an approved backflow prevention device/assembly is required at the customer's water service connection for the safety of the water system, MAWSS shall provide written notice to the customer to install the specified approved backflow prevention device(s)/assembly(ies) at specific location(s) on the premises. Unless otherwise specified by MAWSS in the notice, the Customer shall install and test the backflow prevention assembly within 180 days from the time the notice is issued.

MAWSS reserves the right to discontinue service to any customer who fails to comply with this policy.

**B. Customer**

The customer is responsible for preventing contaminants and pollutants from his/her water systems from entering the public potable water supply. If the customer receives notice that an approved backflow prevention device(s)/assembly(ies) is required, the customer shall install such approved device(s)/assembly(ies) with the help of a certified installer, at the customer's expense. After installation, the customer shall have the device(s)/assembly(ies) tested by a certified tester, except for residential connections per Section 6.05.C, and the device(s)/assembly(ies) shall be maintained satisfactorily. Customer shall comply with all provisions of the Program. Failure, refusal, or inability for the customer to install, test, and maintain the backflow prevention device(s)/assembly(ies) within 180 days of receiving the notice from MAWSS shall constitute grounds for discontinuing water service to the premises until such requirements have been met. Refer to Appendix B for a detailed checklists of customer requirements in accordance with MAWSS policy.

**C. Tester**

Backflow prevention assembly testers shall be certified and have completed the required training courses as described in Section 6.15, Testing and Repairs of Backflow Prevention Assemblies. Tests shall be performed only by testers preapproved by MAWSS and included in their approved contractor list located on MAWSS website.

**6.07 Additional Rules for Protection of MAWSS Water Supply System**

The City of Mobile and the Mobile County Public Health Department have adopted the most current edition of the International Plumbing Code. Sections 608.6 and 608.13 of the Code address cross connection control and backflow prevention requirements. Section 607.3, Thermal Expansion Control, requires that thermal expansion control devices be installed in the plumbing of a building when backflow prevention devices/assemblies are installed, and thus, the customer is responsible for complying with this requirement.

Section 912.5 of the International Fire Code requires that potable water supply to automatic sprinkler and standpipe systems be protected against backflow as required by the International Plumbing Code.

ADEM Code R. 335-7-9-03 requires the installation of backflow prevention devices on all service connections and discontinuance of service to a customer if a suitable device is not installed or properly maintained. All new and existing buildings and homes connected to the MAWSS water supply shall have backflow prevention devices/assemblies installed. If existing buildings or homes do not currently have a backflow prevention device installed, one shall be installed in accordance with this document.

### **6.08 Description and Causes of Backflow**

Backflow is the undesirable reversal of flow of used water or mixtures of water and other liquids, gases, or other substances through a cross-connection and into the distribution pipes of a public potable water system or the customer's potable water system.

#### **A. Back-siphonage**

ADEM Code R. 335-7-7.02, requires that a minimum residual pressure of 20 pounds per square inch (psi) is supplied at the water system meter under all normal operating conditions. This ensures the proper operation of fixtures and appliances, and provides a positive pressure buffer to prevent the possibility of creating a siphon with negative pressure.

Backflow from back-siphonage occurs when a subatmospheric pressure (less than 0 psig) occurs in the piping system. Typical conditions or arrangements that may cause back-siphonage include high-demand conditions, such as a fire flow; customer demand during heat-wave emergencies; pipe corrosion that significantly reduces pipe capacity; water main breaks; and service interruptions.

#### **B. Backpressure**

Water flows from high pressure to low pressure. Thus, if the water pressure of a customer's plumbing system exceeds that of the public distribution system, backflow will occur if a backflow preventer is not installed. Common causes or sources of back pressure include pumps, elevated piping, thermal expansion, pressurized containers, and process water systems.

Backflow prevention devices/assemblies can create a closed-piping system on the customer's premises, and thus these systems must have a means to safely accommodate or relieve the effects of excessive pressure caused by the thermal expansion of water in the system. Boilers and water heaters are sources of thermal expansion backpressure.

### **6.09 Approved Backflow Prevention Methods**

There are five basic types of devices that can be used to correct cross-connections including double check valve assemblies, dual check valves, and reduced pressure principle assemblies. In general, all manufacturers of these devices produce them to one or more of three standards, thus ensuring the public that dependable devices are being utilized. The major standards are

the American Society of Sanitary Engineers (ASSE), American Water Works Association (AWWA), and the University of California Foundation for Cross-Connection Control and Hydraulic Research. Approved backflow prevention methods are described below. Refer to Section 6.13, Installation of Assemblies and Standard Details, for additional details.

**A. Double Check Valve Assemblies**

All double check valve backflow prevention devices or assemblies include two single check valves coupled to act as a backup in the event that the second check valve is not working. The variations of double check valve backflow prevention devices and assemblies is discussed below.

**(a) Double Check Valve Assembly (DCVA)**

A double check valve assembly consists of two independently operating, approved check valves coupled within one body and furnished with four test cocks and two resilient-seated gate valves, one upstream and one downstream of the double check valve. The test cocks allow each check valve to be tested to determine if either or both check valves are inoperative or fouled by debris. Each check valve is capable of holding a minimum of 1 psi in the direction of flow of the check valve. Figure 1 shows a cross section of the double check valve assembly. A double check valve assembly may be used under continuous pressure, and protect against back-siphonage and backpressure conditions for low hazard applications. A pipeline should be thoroughly flushed before a double check valve is installed to ensure that no dirt or debris is delivered into the assembly. The double check valve assembly shall be installed where it can easily be field tested and repaired as necessary. Refer to the Double Check Valve Assembly Standard Detail in Appendix C for additional installation requirements.

**Figure 1. Double Check Valve Assembly (Section)  
(AWWA, Water Transmission and Distribution, Second Edition)**

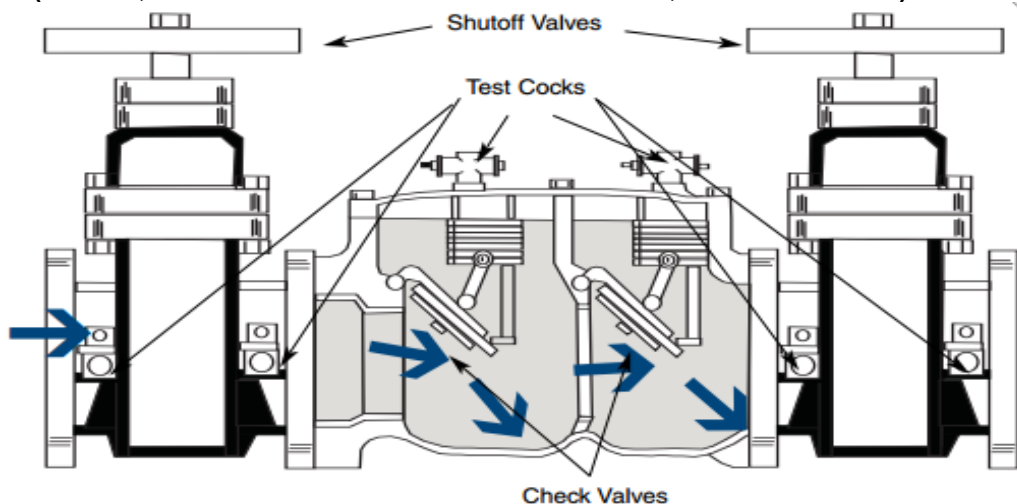

**(b) Double Check Valve Detector Backflow Prevention Assembly (DCDA)**

The double check valve detector backflow prevention assembly consists of a main-line double check valve with a bypass arrangement around the main-line double check valve that contains a water meter and a double check valve. A second type of

double check valve detector assembly (Type II) has the bypass arrangement bypassing the second main-line check valve only, providing a shared first check valve for both the main-line and bypass arrangements. This assembly is primarily used in fire line installations to protect the potable supply and detect any water movement in the fire line. The bypass is designed to detect the first 2 gallons per minute (gpm) of flow through the assembly to show any unauthorized usage or leaks in the fire protection system. Figure shows a cross section of the DCDA. This assembly can protect against backpressure and/or back-siphonage and can be used only for low hazard applications. The pipeline should be thoroughly flushed before a double check valve assembly is installed to ensure that no dirt or debris is delivered into the assembly. Refer to the Double Check Valve Detector Check Assembly Standard Detail in Appendix C for additional installation requirements.

**Figure 2. Double Check Valve with Detector Assembly (Section)**

*Source: USEPA Cross-Connection Control Manual (2003)*

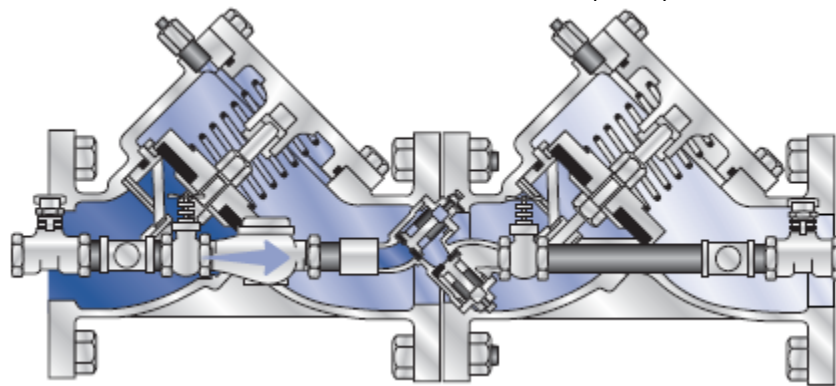

**B. Residential Dual Check (RDC) Valve**

The residential dual check valve contains two internally loaded, independently operating check valves to provide backpressure and back-siphonage protection for individual residences. Unlike the double check valve assembly, the residential dual check valve does not contain test cocks and gate valves. Debris or deterioration of the check components can affect both checks without an outward indication of failure. Thus, the pipeline should be thoroughly flushed before a dual check valve is installed to ensure that no dirt or debris is delivered into the device.

Figure shows a cross-section of the residential dual check valve. Refer to the Residential Dual Check Valve Standard Detail in Appendix C for additional installation requirements.

**Figure 3. Residential Dual Check Valve (Section)**  
Source: USEPA Cross-Connection Control Manual (2003)

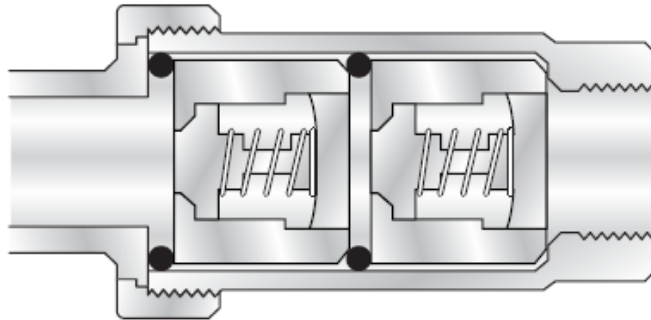

Typically, residential plumbing systems are smaller than most commercial plumbing systems. Thus, the adverse effects of thermal expansion can be greater and more immediate. As required with any closed system, thermal expansion protection that meets local plumbing code must be installed and maintained to ensure the safety and longevity of the private plumbing system. Refer to Appendix D for additional thermal expansion protection information.

**C. Reduced-pressure Principle Backflow Prevention Assembly (RPBA)**

A reduced-pressure principle backflow prevention assembly contains two internally loaded, independently acting check valves with a hydraulically operating, mechanically independent differential pressure relief valve (atmospheric vent) located below the first check valve. The pressure relief valve may periodically blow-off water, and thus, accommodations shall be provided. The check valves and the relief valve shall be located between two tightly closing, fully ported, resilient-seated shutoff valves. The “zone” between the two check valves is always kept at least 2 psi less than the supply pressure. The RPBA shall have four properly located resilient-seated test cocks. This assembly provides maximum protection against back-siphonage and backpressure conditions and can be used for both high and low hazard applications. Figure 4 shows a cross section of the reduced-pressure principle backflow prevention assembly. The pipeline should be thoroughly flushed before a reduced-pressure principle backflow assembly is installed to ensure no dirt or debris is delivered into the assembly. Refer to the Reduced Pressure Principle Backflow Prevention Assembly Standard Detail in Appendix C for additional installation requirements.

**Figure 4. Reduced-pressure Principle Backflow Prevention Assembly (Section)**  
Source: USEPA Cross-Connection Control Manual (2003)

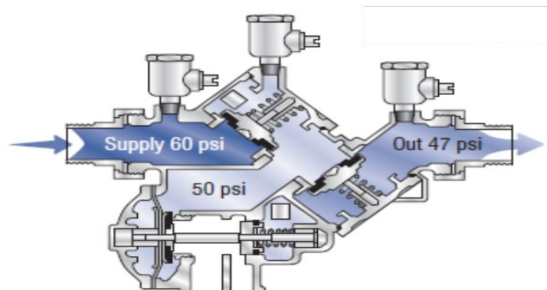

**D. Reduced-pressure Principle Detector Backflow Prevention Assembly (RPDA)**

The reduced-pressure principle detector backflow prevention assembly consists of a main-line reduced-pressure principle backflow prevention assembly with a bypass arrangement around the main-line reduce-pressure principle assembly that contains a water meter for detection and a reduced-pressure principle assembly. The pressure relief valves may periodically blow-off water, and thus, accommodations shall be provided. This assembly is designed for fire-protection systems in which a main-line meter is not used, but leaks or unwanted usage need to be detected. The bypass is designed to detect the first 2 gpm of flow through the assembly to show any unauthorized usage or leaks in the fire protection system. Figure 5 shows a reduced-pressure principle detector backflow prevention assembly. This assembly can protect against backpressure and/or back-siphonage and can be used for both high and low hazard applications. The pipeline should be thoroughly flushed before a reduced-pressure principle detector backflow assembly is installed to ensure no dirt or debris is delivered into the assembly. Refer to the Reduced Pressure Principle Detector Assembly Standard Detail in Appendix C for additional installation requirements.

**Figure 5. Reduced-pressure Principle Detector Backflow Prevention Assembly (Photo)**

*Source: Watts Regulator Co.*

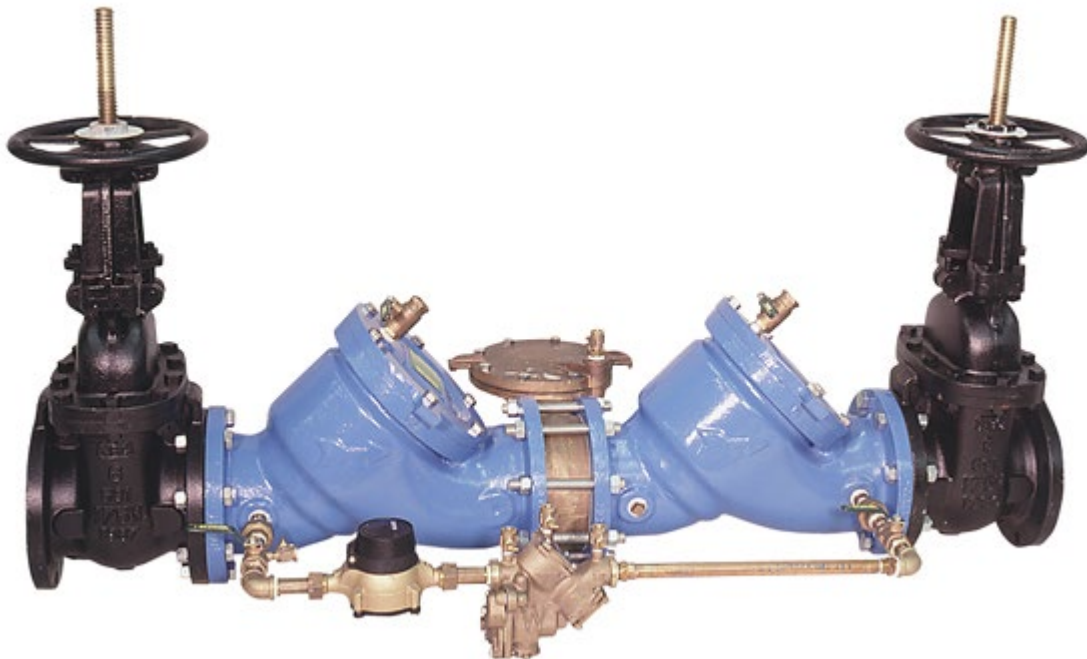

### **6.10 Backflow Prevention Selection Criteria**

The type of backflow prevention device/assembly required depends on the degree of hazard that exists on the customer's premises. The degree of hazard increases as a function of both the probability that backflow will occur and the toxicity of the substance that may backflow. Table 1 presents the degree of hazards and their definitions. A low degree of hazard (non-health hazard) may include a pollutant that impacts the aesthetic qualities of potable water. A high degree of hazard (health hazard) may include acute microbial to acute chemical to chronic

chemical contamination. Additionally, any water that leaves the control of the water supplier should be considered at risk for contamination.

**Table 1. Potential Backflow Hazards**

Degree of Hazard	Definition
Non-Health Hazard	A cross-connection or potential cross-connection involving any pollutant that if introduced into the potable water system as a result of a backflow situation may cause cosmetic effects (such as skin or tooth discoloration) or aesthetic effects (such as taste, odor, or appearance), as listed in the EPA National Secondary Drinking Water Standards.
Health Hazard	A cross-connection or potential cross-connection involving a contaminant that could, if introduced into the potable water supply, cause death or illness, spread disease, or have a high probability of causing such effects. An example of a contaminant would be any that is identified in the National Primary Drinking Water Standards.

In addition to the potential hazard of a cross-connection, the type of backflow (backpressure, back-siphonage, or both) that may occur is another factor to consider when selecting a backflow prevention assembly. Backpressure conditions must be considered when assessing actual or potential cross-connection conditions. Back-siphonage is evaluated primarily as a potential condition.

In assessing the degree of hazard of a cross-connection, MAWSS shall focus on the overall hazard posed by a customer's entire plumbing system when considering a requirement for service connection protection. The type of approved backflow prevention assemblies that may be required (listed in order of increasing protection) includes: double check valve assembly or reduced pressure backflow assembly. Residential dual check valves shall also be approved for the appropriate cross-connections. The customer may choose a higher level of protection than that required by this policy. Table 2 presents backflow prevention devices/assemblies and their application for degree of hazard and type of backflow.

**Table 2. Means of Backflow Prevention**

Device/Assembly	Degree of Hazard			
	Non-Health Hazard		Health Hazard	
	Back-Siphonage	Back-pressure	Back-Siphonage	Back-pressure
Double check valve assembly (DCVA)	X	X		
Reduced-pressure principle assembly (RPBA)	X	X	X	X

Reduced-pressure principle detector assembly (RPDA)	X	X	X	X
Double check valve detector check assembly (DCDA)	X	X		
Residential dual check (RDC) valve device	X	X		

## 6.11 Facilities Requiring Backflow Prevention Assemblies

A detailed list of facilities and their appropriate backflow prevention device/assembly is presented in Appendix E. Situations that are not covered in this policy shall be evaluated on a case-by-case basis, and appropriate backflow prevention shall be determined by MAWSS. If MAWSS determines that a premise presents a pollutant or a contaminant risk (actual or potential) to the public potable water supply system, MAWSS shall require the customer to isolate such premises through the use of appropriate backflow prevention devices.

### A. Fire Protection Systems

All fire protection systems that are connected to the public potable water supply system on the property side of the potable water service shall be isolated with an approved backflow prevention assembly. The level of backflow protection shall be commensurate with the degree of hazard. The following are descriptions of those situations that determine the different fire systems hazards, and the minimum acceptable type of backflow protection required.

### B. High-Hazard Fire Systems

A reduced-pressure principle backflow/detector assembly (RPDA) shall be required for high-hazard fire systems. High-hazard fire systems include those where an unapproved auxiliary water supply is connected to a fire system or is in close proximity and intended for use by fire pumper trucks. High-hazard fire systems also include those that allow chemical addition or antifreeze.

### C. Low-Hazard Fire Systems

A double check valve detector assembly (DCDA) shall be required for low hazard fire systems. This category includes all fire systems not included under "High-Hazard Fire Systems".

### D. Premises Isolation

MAWSS shall require a backflow prevention assembly at the service connection to isolate an entire premise where a potential cross connection could constitute a health or non-health hazard to the public potable water supply system. MAWSS is not responsible for the prevention of cross-connections internal to the customer's premises.

### E. Health Hazard

An approved reduced-pressure principle backflow prevention assembly shall be required for customer premises that fall into the classification of an actual or potential



health hazard. Example premises include hospitals, laboratories, chemical plants using water, car washing facilities, and food and beverage processing plants. Refer to Appendix E for a complete list of facilities and their appropriate backflow prevention device/assembly.

**F.** Non-Health Hazard

Premises that have the potential to generate backpressure shall be isolated from the public water supply. An approved double check valve backflow prevention assembly shall be required for customer premises that fall into the classification of an actual or potential non-health hazard. Example premises include buildings that exceed 40 feet in height and multi-storied building that use booster pumps.

## **6.12 Approved Backflow Prevention Assemblies**

Approved backflow prevention assemblies shall be in compliance with the standards set forth by ANSI/AWWA C510 and C511 and the University of Southern California Foundation of Cross-Connection Control and Hydraulic Research (FCCCHR) Manual of Cross-Connection Control, Tenth Ed. A list of manufacturers and models approved by MAWSS can be found in Appendix F.

## **6.13 Installation of Assemblies and Standard Details**

**A.** General

Refer to Appendix B, Customer Checklists, for customer's responsibilities during the installation of backflow prevention assemblies.

All backflow prevention assemblies shall be new when installed and installed in strict accordance with manufacturer's instructions. The backflow prevention assembly shall be located in the service line immediately following the water meter and upstream of any pipes branching off of the main service line. Any other locations must be approved by MAWSS before installing the assembly. Requests for inside placement of the assembly will be considered in situations where lack of available space warrants (primarily in the Downtown area). Aesthetics shall not be considered a reason to locate the assembly anywhere other than adjacent to the meter. Sufficient access for testing and repairs shall be provided for all applications. Installation standard details for the backflow prevention assemblies and devices are included in Appendix C.

Backflow prevention assemblies installed on fire protection systems shall comply with the latest edition of the International Fire Code requirements or latest adopted version. All valves controlling the water supply for automatic sprinkler systems shall be electrically supervised by a listed fire alarm control unit. Alarm, supervisory, and trouble signals shall be distinctly different and shall be automatically transmitted to an approved supervising station or, when approved by the fire code official, shall sound an audible signal at a constantly attended location. Backflow prevention assembly test valves located in limited area sprinkler system supply piping shall be locked in the open position. In occupancies required to be equipped with a fire alarm system, the backflow preventer valves shall be electrically supervised by a tamper

switch installed in accordance with NFPA 72 and separately annunciated. The local fire marshal shall have jurisdiction over fire lines on premises and should be contacted for applicable codes before installing assemblies.

The customer shall procure the services of a certified contractor, pre-approved by MAWSS. A list of the contractors is provided on the MAWSS website under the Cross Connection Control Program.

Backflow prevention assemblies installed above ground and outdoors shall be equipped with the appropriate security and protected from freezing temperatures. Assembly enclosures can be utilized for freeze protection as well as aesthetics and security. Outdoor enclosures for backflow prevention assemblies shall comply with the freeze protection and enclosure requirements of ASSE 1060.

Below are examples of different types of methods for providing security, freeze protection, and improved aesthetics. Insulation materials for backflow prevention assemblies shall comply with ASTM standards.

***Examples of Security for Backflow Prevention Devices***



***Double Check Valve Assembly with Secured Valves Operators***



***Residential Backflow Prevention Assembly with Locked Enclosure***



***Double Check Valve with Valve Operation Alarm Switches and Insulation***

***Examples of Freeze Protection for Backflow Prevention Devices***



*Freeze-protected Aluminum Enclosure Over Backflow Prevention Assembly*



*Freeze-protected Fiberglass Enclosure Over Backflow Prevention Assembly*



*Double Check Valve with Pipe and Valve Insulation*

### ***Examples of Improved Aesthetics for Backflow Prevention Devices***



*Faux Rocks Covering Backflow Prevention Assemblies*



*Bushes Screening Backflow Prevention Assembly*

#### **6.14 Backflow Prevention Assembly Removal**

Approval must be obtained from MAWSS before a backflow prevention assembly is removed, relocated, or replaced. Changes to assemblies that service fire prevention systems shall also require approval of the Mobile Fire and Rescue Department (251-208-7484).

**A.** Removal

The use of an assembly may be discontinued and the assembly removed from service upon presentation of sufficient evidence to MAWSS to verify that a hazard no longer exists.

**B.** Relocation

An assembly may be relocated following confirmation by MAWSS that the relocation will continue to provide the required protection and satisfy the installation requirements. Testing and certification will be required upon relocation.

**C.** Replacement

An assembly may be removed and replaced provided the water use is discontinued until the replacement assembly is installed. All replacement assemblies must be approved by MAWSS and must be commensurate with the degree of hazard involved. An assembly may be removed for repair, provided the water use is discontinued until the repair is completed and the assembly is returned to service. If the water service cannot be discontinued for the time required to replace an assembly, a parallel assembly must be installed prior to the replacement.

## **6.15 Testing and Repairs of Backflow Prevention Assemblies**

Refer to Appendix B, Customer Checklists, for customer's responsibilities during the testing of backflow prevention assemblies.

MAWSS will send a Cross Connection Survey to those existing non-residential and irrigation customers when the potential sources of backflow or the degree of hazards are unknown. The surveys will identify if the customer needs to install a backflow prevention assembly at the service connection. MAWSS will distribute non-compliance emails to inform customers that corrective action is required. If the property is not in compliance, the customer will be required to install and test a MAWSS-approved backflow prevention assembly(ies) by a certified tester within 180 days of the notice, or sooner if otherwise indicated by MAWSS. Failure to provide certification of testing within the 180 days may result in discontinuance of service.

The installed assembly shall be new. MAWSS shall be notified via email at [crossconnection@mawss.com](mailto:crossconnection@mawss.com) at least 1 MAWSS working day prior to the initial installation and testing of the backflow prevention assembly(ies). After the backflow prevention assembly has been tested, the tester shall submit the Backflow Assembly Test Report (see Appendix A) to MAWSS. The Backflow Assembly Test Report shall be emailed to MAWSS through the MAWSS Testing Software found on the MAWSS website under the Cross Connection Control Program. The customer and tester should keep the original or a copy in their records.

The customer is responsible for the cost of tests, maintenance, and/or replacement of the backflow prevention assembly. The customer is also responsible for maintaining good working condition of all backflow prevention assemblies located on premises. MAWSS shall notify the customer that testing is required 180 days prior to each test certification or recertification due date. MAWSS shall notify the customer within 14 days of the end of the 180-day period if the customer's Backflow Assembly Test Report(s) is not received. Failure to provide certification within the 180 days may result in discontinuance of service.

### **A. Requirements of Testing Personnel**

Certified backflow prevention assembly testers shall provide proof of completion of a training course including a minimum of 32 hours as outlined by the AWWA M14 Manual. The training course shall include class room instruction, hands-on experience with various types of backflow prevention assemblies, familiarization with testing equipment from several manufacturers, and the successful completion of a written examination. The course shall be officially endorsed by AWWA or the American Backflow Prevention Association (ABPA).

In addition to the certification course requirements as outlined above, personnel testing backflow assemblies servicing fire lines and sprinkler systems must be a pre-approved, qualified inspection technician, currently on file with the State Fire Marshal's office.

Test reports will not be accepted from testing contractors who are not certified, as required herein, or from testing contractors whose certification has expired, or was not current when the test was performed.

All test equipment shall be checked for accuracy annually, at a minimum, and calibrated, if necessary. The customer shall procure the services of a certified tester

pre-approved by MAWSS. A list of contractors is provided on the MAWSS website.

**B. Testing Frequency**

Unless indicated otherwise, existing and newly installed backflow prevention assemblies shall be tested at the time of installation and at least annually thereafter. MAWSS may require more frequent testing in cases where there is a history of test failure or due to the degree of hazard involved.

**C. Test Reports**

The tester shall submit a Backflow Assembly Test Report for each backflow prevention assembly on the premises through the MAWSS Testing Software found on the MAWSS website under the Cross Connection Control Program. Refer to the Backflow Assembly Test Report in Appendix A.

**D. Repairs**

**Table 3. Summary of Backflow Prevention Assembly Installation and Testing**

<b>Customer Type</b>	<b>Installed By</b>	<b>Type</b>	<b>Testing Frequency</b>	<b>Tested By</b>	<b>Notes</b>
<b>New</b>					
Residential	MAWSS	Residential Dual Check Valve	N/A	N/A	Installed with new meter.
Non-Residential	≤1" Meter – MAWSS >1" Meter – Certified Installer	Depends on potential hazard. If degree of hazard is unknown, install a Reduced-Pressure Principle Assembly	Annual, maybe more frequent depending on hazard	Certified tester	Customer to complete survey report regarding customer plumbing. MAWSS to witness installation and initial testing.
Irrigation	≤1" Meter – MAWSS >1" Meter – Certified Installer	Double Check Valve (may require a Reduced – Pressure Principle Assembly depending on degree of hazard)	Annual	Certified tester	Customer to complete survey report regarding customer plumbing. MAWSS to witness installation and initial testing.
<b>Existing</b>					

Residential	MAWSS	Residential Dual Check Valve	N/A	N/A	
Residential – New Main	MAWSS	Residential Dual Check Valve	N/A	N/A	Issue notice addressing thermal expansion of water heater
Non-Residential	If required: ≤1" Meter – MAWSS >1" Meter – Certified Installer	Depends on potential hazard	Annual, may be more frequent depending on hazard	Certified tester	Complete survey report to obtain existing backflow prevention assembly and other information. MAWSS to witness installation and initial testing. Complete test report.
Irrigation	If required: = 1" Meter – MAWSS > 1" Meter – Certified Installer	Double Check Valve	Annual	Certified tester	Complete survey report to obtain existing backflow prevention assembly and other information. MAWSS to witness installation and initial testing. Complete test report.

If repairs to the backflow prevention assembly(ies) are required based on test results or inspections, the customer will have 30 days from the date of the test report to make the repairs and re-test the assembly(ies). Failure to provide certification within the 30 days will result in discontinuance of service.

The water supply from MAWSS must be valved off and the customer's system isolated before repairs or replacements are performed. If the water service cannot be discontinued for the time required to repair an assembly, a parallel assembly must be installed prior to the repair or replacement. Bypassing the backflow prevention assembly is not permissible.

Repairs shall be performed by a certified repair person and tester who is pre-approved by MAWSS. A list of the contractors is provided on the MAWSS website under the Cross Connection Control Program.

### 6.16 Inspection of Backflow Prevention Assemblies

Authorized employees or agents for MAWSS shall be permitted to enter premises to complete the cross-connection survey with the customer, if necessary, to make inspections of connections to the potable water supply, to witness the backflow prevention assembly testing

performed by a MAWSS-approved certified tester, and to inspect backflow prevention assemblies that are equipped with detection meters. Refusal to allow inspection shall constitute a violation of the Program. The customer shall install a reduced-pressure principle backflow prevention assembly (RPBA) if MAWSS is unable to inspect the existing backflow prevention assembly.

### **6.17 Reports and Records**

The Cross-Connection Survey Report and the Backflow Assembly Test Reports for non-residential and irrigation customers can be found in Appendix A. The customer should keep the original or a copy of these reports in their records.

### **6.18 Non-Compliance with Policy**

As stated in Section 6.03, Statement of Policy and ADEM Code R. 335-7-9-05, water service will be discontinued if the customer fails to comply with this Program. MAWSS retains the authority to immediately disconnect water service if necessary to protect the public water supply.

### **6.19 References**

The following manuals can be consulted for additional information:

- AWWA M14 Manual (Fourth Edition)
- USEPA Cross-Connection Control Manual (2003)
- University of Southern California FCCCHR Manual of Cross-Connection Control (Tenth Edition).

The following codes, which are referenced herein, can also be consulted for additional information:

- International Building Code, Sections 607 and 608
- International Fire Code, Section 912
- Alabama Department of Environmental Management, Section 335-7-9-03
- American Society of Safety Engineers, Standard 1060



**APPENDIX A – FORMS**

Cross-Connection Survey Report

Backflow Assembly Test Report

## **APPENDIX B – CUSTOMER CHECKLISTS**

New Residential Customer Checklist

New Non-Residential (Commercial, Multi-Family, and Industrial) Customer Checklist

New Irrigation Customer Checklist

Existing Residential Customer Checklist

Existing Non-Residential (Commercial, Multi-Family, and Industrial) Customer Checklist

Existing Irrigation Customer Checklist

**APPENDIX C – STANDARD DETAILS**

**APPENDIX D – THERMAL EXPANSION PROTECTION**



# Thermal Expansion Modifications

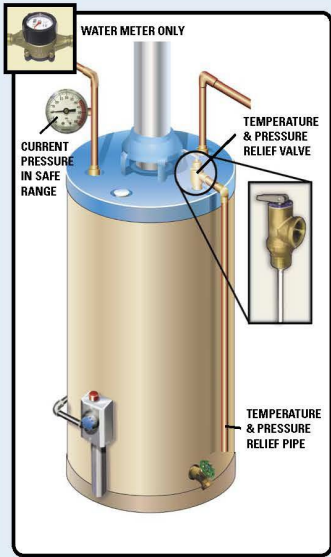

**CURRENT CONFIGURATION**

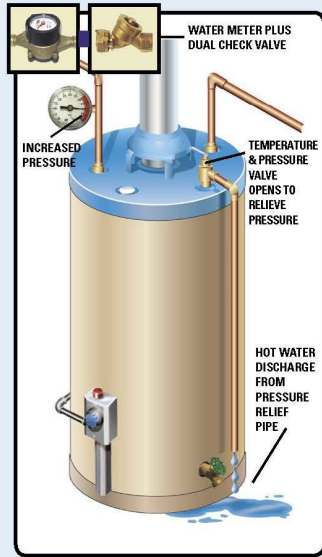

**DUAL CHECK VALVE  
INSTALLED AT METER**

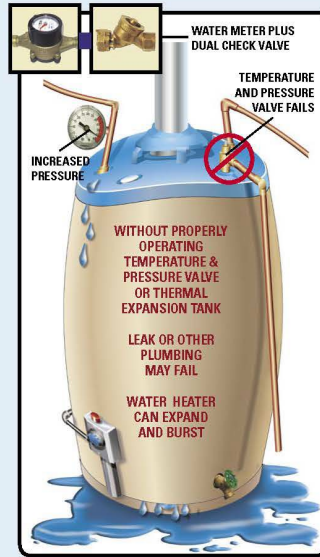

**DUAL CHECK VALVE  
WITHOUT  
THERMAL EXPANSION TANK  
TEMPERATURE AND PRESSURE  
RELIEF VALVE FAILS**

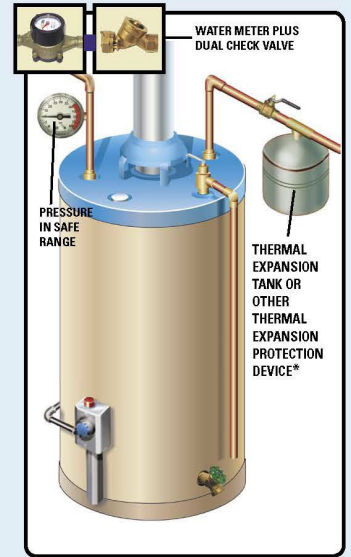

**DUAL CHECK VALVE AND  
THERMAL EXPANSION TANK  
INSTALLED**

\* THE PLUMBING CODE REQUIRES INSTALLATION OF A THERMAL EXPANSION PROTECTION (T.E.P.) DEVICE IF A DUAL CHECK VALVE IS INSTALLED AT THE METER. THE TEMPERATURE & PRESSURE VALVE CAN FAIL RESULTING IN PLUMBING DAMAGE IF NO T.E.P. DEVICE IS INSTALLED.

**APPENDIX E – FACILITIES REQUIRING BACKFLOW PREVENTION**

**Customer Categories and Backflow Prevention Type**

<b>Category</b>	<b>Type</b>	<b>Degree of Hazard</b>
Aircraft and missile plants	RPBA	High
Automotive plants	RPBA	High
Auxiliary Water	RPBA DCVA	High Low
Car wash	RPBA	High
Chemical plants; oil and gas production or transmission properties; dye works; film laboratories; plating facilities; manufacturing	RPBA	High
Dairies and cold storage plants	RPBA DCVA	High Low
Fire protection systems	RPBA DCVA	High Low
Food-processing and beverage-bottling facilities	RPBA	High
Hospital	RPBA	High
Mortuary; medical centers; medical, dental, and veterinary clinics	RPBA DCVA	High Low
Irrigation system <sup>1</sup>	DCVA	Low
Laboratory	RPBA	High
Marine Facilities and Dockside Watering Points	RPBA	High
Radioactive material processing plants	RPBA	High
Residential Water Services	RDC	Low
Sewage treatment plants and sewage lift stations	RPBA	High
Schools and colleges	RPBA DCVA	High Low
Water-Hauling Equipment	RPBA	High

Notes:

RPBA=Reduced Pressure Principle Backflow Assembly

RPDA=Reduced Pressure Principle Detector Backflow Assembly

DCVA=Double Check Valve Assembly

DCDA=Double Check Detector Assembly

RDC=Residential Dual Check Valve Device

<sup>1</sup>Typically a double check valve assembly will be required for irrigation, but an assembly providing greater protection, such as a reduced pressure backflow assembly, may be required depending on internal connections to the irrigation system (for example, chemical feed system).

**APPENDIX F – APPROVED BACKFLOW PREVENTERS**

**Double Check Valve Assembly**

<b>Manufacturer</b>	<b>Meter Size</b>	<b>Model No.</b>
Ames	½", ¾", 1"	2000 B
Ames	1.25"	2000 B
Ames	1.5", 2"	2000 B
Ames	¾"	200 BM3
Ames	4"	2000 CIV
Ames	6", 8", 10"	2000 CIV
Cla- Val	¾"	DC6LB
Cla- Val	2.5", 3", 4", 6"	DC8VW
Cla- Val	8"	DC8VW
Cla- Val	10"	DC8VW
Cla- Val	2.5", 3", 4", 6"	DC8VY
Cla- Val	8"	DC8VY
Cla- Val	10"	DC8VY
Cla- Val	4", 6"	DC8LW
Cla- Val	4", 6"	DC8LY
Conbraco	½"	½ DC
Conbraco	2.5"	2 ½ DC
Conbraco	3"	3 DC
Conbraco	4"	4 DC
Conbraco	6"	6 DC
Febco	¾"	805 YB
Febco	½", ¾", 1"	850
Febco	1.25", 1.5", 2"	850
Febco	2.5", 3"	850
Febco	4", 6", 8"	850
Febco	1/2", ¾", 1"	850 U
Febco	1.25", 1.5", 2"	850 U
Febco	2.5", 3", 4", 6"	870 V
Febco	8", 10"	870 V
Watts	2-1/2", 3"	007
Watts	½"	007 QT
Watts	1"	007 M1QT
Watts	2"	007 M1QT
Watts	¾"	007 M2QT

### Double Check Valve Assembly

Manufacturer	Meter Size	Model No.
Watts	1-1/4"	007 M2QT
Watts	1-1/2"	007 M2QT
Watts	1-1/4"	007 M2PCQT
Watts	3/4"	007 M3QT
Watts	1/2"	U007 QT
Watts	1"	ss007 M1QT
Watts	1/2", 3/4"	ss007 M3QT
Watts	4"	709
Watts	6", 8", 10"	709
Watts	1/2", 3/4"	775 QT
Watts	1"	775 QT
Watts	1.25", 1.5"	775 QT
Wilkins	4", 6", 8"	950
Wilkins	4", 6"	950 G
Wilkins	3/4"	950 XL
Wilkins	3/4"	950 XLD
Wilkins	4"	350
Wilkins	6"	350
Wilkins	6"	350 G

### Double Check Valve Detector Assembly

Manufacturer	Meter Size	Model No.
Ames	2"	3000 B w/ Ames 1/2 2000 B Watts 007QT 1/2"
Ames	4"	3000 CIV w/ Ames 1/2 2000 B, Watts 007QT 1/2"
Ames	6", 8", 10"	3000 CIV w/ Ames 1/2 2000 B, Watts 007QT 1/2"
Cla-Val	4", 6"	DD8LY w/ Cla-Val DC6LB
Cla- Val	2-1/2", 3", 4", 6"	DD8VY w/ Cla-Val DC6LB
Cla- Val	8"	DD8VY w/ Cla-Val DC6LB

### Double Check Valve Detector Assembly

Manufacturer	Meter Size	Model No.
Cla- Val	10"	DD8VY w/ Cla-Val DC6LB
Febco	2-1/2", 3"	856 w/ Febco 850 YB
Febco	4", 6"	856 w/ Febco 850 YB
Febco	8"	856 w/ Febco 850 YB
Febco	2-1/2", 3", 4", 6"	876 V w/ Febco 850 YB
Febco	8"	876 V w/ Febco 850 YB
Febco	10"	876 V w/ Febco 850 YB
Watts	2"	007 DCDA w/ Watts 007QT
Watts	2-1/2"	007 DCDA w/ Watts 007M2QT
Watts	4"	709 DCDA w/ Watts 007QT
Watts	6", 8", 10"	709 DCDA w/ Watts 007QT
Wilkins	4"	350 DA w/ Wilkins 950XLD
Wilkins	6"	350 DA w/ Wilkins 950XLD
Wilkins	6"	350 DAG w/ Wilkins 950XLD
Wilkins	2-1/2", 3", 6"	950 DA w/ Wilkins 950XL
Wilkins	4", 8"	950 DA w/ Wilkins 950XL
Wilkins	4"	950 DAG w/ Wilkins 950XL
Wilkins	6"	950 DAG w/ Wilkins 950XL



### Reduced-Pressure Principle Assembly

Manufacturer	Model No.	Meter Size
Wilkins	375, 475 & 475V	2-1/2" – 6"
Wilkins	975XL	1/4" - 1/2"
Wilkins	975XL	3/4"-2"
Wilkins	975	2-1/2"-10"
Ames	4000ss & 5000ss 7	2-1/2"-6
Ames	4000ss & 5000ss	2-1/2"-6
Conbraco	40-200	1/4"-2"
Conbraco	40-100DCV	2-1/2"-4"
Conbraco	40-200RPZ	2-1/2"-4"
Conbraco	RPZ	2-1/2"-10"
Febco	805 & 825Y	3/4"-2"
Febco	860 & 880	2-1/2"-10"
Watts Series	009	1/4"-2"
Watts Series	009	2"-1/2"-3"
Watts Series	909	3/4"-2"
Watts Series	909	2"-1/2"-10"
Flomatic	RPZ	3/4"-2"
Flomatic	RPZII	1/2", 3/4", 1-1/2"
Flomatic	RPZ	2-1/2"-8"
Cla-Val	RP-2	3/4" & 1"
Cla-Val	D-2	1-1/4" & 2"
Cla-Val	3081, 3081EX, and 3084	2"-10"

## SECTION 7

### WATER/WASTEWATER MAIN EXTENSIONS AND METER CONVERSIONS

#### 7.1 General

It is the policy of the Board to encourage and assist in the extension of water and/or wastewater mains to the property or properties of any person or entity requesting those services, except as limited by state or local law. Other limitations of this policy are related to: 1) reasonableness of how the proposed extension fits into MAWSS' plan and schedule for providing service to the community, and 2) funding priority. Reasonableness of the project will be evaluated in terms of work that would reduce capital costs and enhance system operating efficiency over anticipated long-term system support of community growth. The level of extension funding is established in an annual budget.

The main extension policy is the same for water and wastewater service, but different in specific applications with regard to two categories of service. The first category is extensions to undeveloped or recently developed properties. In these circumstances, the development is linked to the anticipated extension in that one would not exist without the other. The second category is extensions to existing communities or areas where residents or businesses use other water and/or sewer facilities, or use temporary mains provided by MAWSS.

For both categories of extensions, it is the applicant's responsibility to furnish information to MAWSS for evaluation of the system's ability and the required improvements to provide the requested service.

It is also the policy of the Board to allow the conversion of apartment complexes from a single master meter to individual meters for each unit. The method of accomplishing this conversion is detailed in section 7.11.

#### 7.2 Definitions

**A.D.E.M.** means the State of Alabama Department of Environmental Management.

**A.D.O.T.** means the Alabama Department of Transportation.

**Adjacent** means no intervening, etc.

**Dual Service Line** is a pipeline that extends from the main to the customer's premises and the pipeline is used for both fire protection and other needs including domestic and industrial process uses. Dual service lines are metered and billed according to consumption.

**Enhanced Size** means mains sized larger than 12-inch to accommodate future long-range development.

**Fire Hydrant Assembly** means the pipe, isolating valves, fittings, hydrants, and the tee on MAWSS' distribution main, needed to provide a fire hydrant.

**Fire Line** is a pipeline that extends from the main to the customer's premises for the sole purpose of providing water to fire suppression systems like sprinklers, hydrants and standpipes. Fire lines are usually fed with potable water; however, industrial customers may use raw water for fire protection where raw water is available. Dedicated fire lines are billed according to the fire service charge – standby charge.

**Laterals** mean all pipes of MAWSS which extend from the sewer collection line to the owner's property line.

**Main** means that pipe which is owned or intended to be owned by MAWSS to which service lines or laterals may be connected.

**Off-Site Mains** mean those mains located outside a development.

**On-Site Mains** mean those mains located in streets, rights-of-way, or easements within a development, and those mains located in streets that are peripheral to a development which are constructed for use by that development but are owned and operated by MAWSS.

**Plumbing** means all pipes, fittings, and appurtenances on the owner's side of the water meter or, in the case of sewer, all lines on the owner's property that serve the premise.

**Property** means that portion of the ground for which either a homestead exemption is claimed or exhibits any physical evidence of use.

**Restrictive Covenant** means a legal document establishing restriction of change in conditions at a premise or location to which service is provided, with covenants to meet specific circumstances, as determined by MAWSS.

**Service Lines** mean the pipes of MAWSS which extend from the water main to the meter, including the corporation stop on the water main, the curb stop at the meter, the meter box, and the backflow preventer or meter coupling.

**Water/Wastewater Main Extension** means a pipeline added to an existing water/wastewater main of MAWSS for the purpose of serving one or more customers.

### **7.3 Water/Wastewater Main Extensions, When Required**

The Owner or Developer shall be advised by MAWSS as to whether water or sewer service is available and whether a water or sewer main extension shall be required. That notification shall not constitute assurance of water or sewer service, which shall be conditioned upon compliance with the rules of MAWSS and the terms and conditions of any contract which may be entered into between the owner or developer and MAWSS, and the availability of sewage treatment or water supply pursuant to the requirements of federal, state, and local agencies.

Water main extensions shall be required when there are no existing water mains to a development or when MAWSS has determined the existing mains are not of adequate size to provide service for that development.

Sewer main extensions shall be required when there are no existing sewer mains to a development or when MAWSS has determined the existing mains are not of adequate size to provide service for that development.

MAWSS shall stipulate the location, length, type, and size of all mains to be installed for the projects to be served, in accordance with accepted, standard engineering practices of the American Water Works Association (AWWA), Water Environment Federation (WEF) and all applicable local, state, and federal requirements.

MAWSS routinely receives requests for water and/or sewer service at locations not presently served by water or sewer mains. The following procedure provides a means of providing service to these locations:

- Step 1:** Customer requests water and/or sewer service at a location not presently served by water and/or sewer mains.
- Step 2:** MAWSS determines water/sewer availability and requirements.
- Step 3:** MAWSS prepares (or reviews and approves) plans, determines enhancement costs, if any, and advises the requester of the cost of a permanent main extension. Should a permanent extension not be justified, the requester may obtain temporary service subject to the following stipulations:
  - A. MAWSS agrees that temporary service is an acceptable method of service to the location and agrees to construct and maintain the temporary service.
  - B. The requester shall pay capacity fees and must also bear the full cost of construction for the temporary service. All easements and/or rights-of-way are to be surveyed and staked by a Registered Land Surveyor at the expense of the requester. A certified plat of the easement and/or right-of-way shall be provided to MAWSS. Easements shall be provided in accordance with MAWSS' Standard Specifications. In the event that the permanent service occupies the same easement and/or right-of-way as the temporary service, MAWSS will reimburse the requester the cost of the survey.
  - C. In the event that permanent service is installed to the requester's property, the requester shall immediately, at his expense, connect to the permanent service. The requester shall be allowed to utilize the temporary service for a minimum of five years, following its construction. However, at the end of five years, the requester shall connect to permanent service, should it be available.
  - D. It shall be expressly understood that fire protection may not be afforded by a temporary water service. The purpose of a temporary water service shall be to provide water for domestic consumption only, and sufficient volume, and/or pressure, for other uses is not assured.

- E. In the event that an additional party requests service from the main which was constructed at the expense of the requester, the requester shall be reimbursed 20% of the construction costs of the temporary service for each party so served. In no event shall the requester be reimbursed more than 80% of the cost of constructing the temporary service. In no event shall the requester be reimbursed for additional connections which occur more than Ten years after construction of the temporary main.
- F. All temporary sewer mains constructed shall be force mains. The requester shall be responsible for the purchase, installation, operation, and maintenance of a grinder pump system which will discharge requester's wastewater into the force main. If permanent service to the location, when constructed, will be a gravity sewer main, the requester shall pay charges applicable to a gravity system.

#### **7.4 Water/Wastewater Main Extension Procedure – New Developments**

An application for a main extension, in a format provided by MAWSS, shall be submitted and signed by the owner/developer desiring such service. MAWSS shall conduct all reviews and communication regarding the project only with the applicant, unless the applicant designates an authorized agent, in writing. The application shall be approved by a professional engineer registered in the State of Alabama, and include the following information:

1. Name, address, and signature of the owner or developer.
2. Adequate legal description and recorded plat of the premises for which service is desired.
3. Building permits from the appropriate county or municipal authorities.
4. For recorded subdivision, a copy of the recorded plat.
5. For new subdivisions, an approved tentative plat, or a master tentative plat or large-scale development plan; a preliminary plan indicating the location of the proposed main extensions within rights-of-way or utility easements; and proof of zoning.
6. For all projects, except an individual owner constructing a single-family residence, 5 complete sets of drawings, which shall include site plans, with minimum five-foot contours, and shall indicate all proposed on-site main extensions, respective of long-term plans.
7. A statement indicating whether the applicant wishes to convey to MAWSS the mains within the non-dedicated areas of the development.

Upon review and approval of the plans submitted and MAWSS' determination that an adequate supply of water and/or sewer service is available, MAWSS will determine the need to oversize the service extension and to make other allowance for future extensions beyond the subject property, and will develop a description and construction cost estimate of the difference, if any, between the base and oversized project. The applicant can then proceed at any time with constructing the oversized extension, with specified MAWSS review and inspection. MAWSS will reimburse the applicant 100% of the enhancement or over sizing cost when the project is accepted by MAWSS.

If the project schedule is coordinated with MAWSS' budget and planning process and the work is directed by MAWSS, the applicant will be required to pay actual project costs less Board contribution and less 100% of the enhancement or over sizing cost. Depending on project size and construction time, these costs can be paid prorated over the actual time expenses are incurred, but in all cases, full payment is required before the project is placed in service.

SEE NEXT PAGE

## MAIN EXTENSION PROCESS NEW DEVELOPMENT

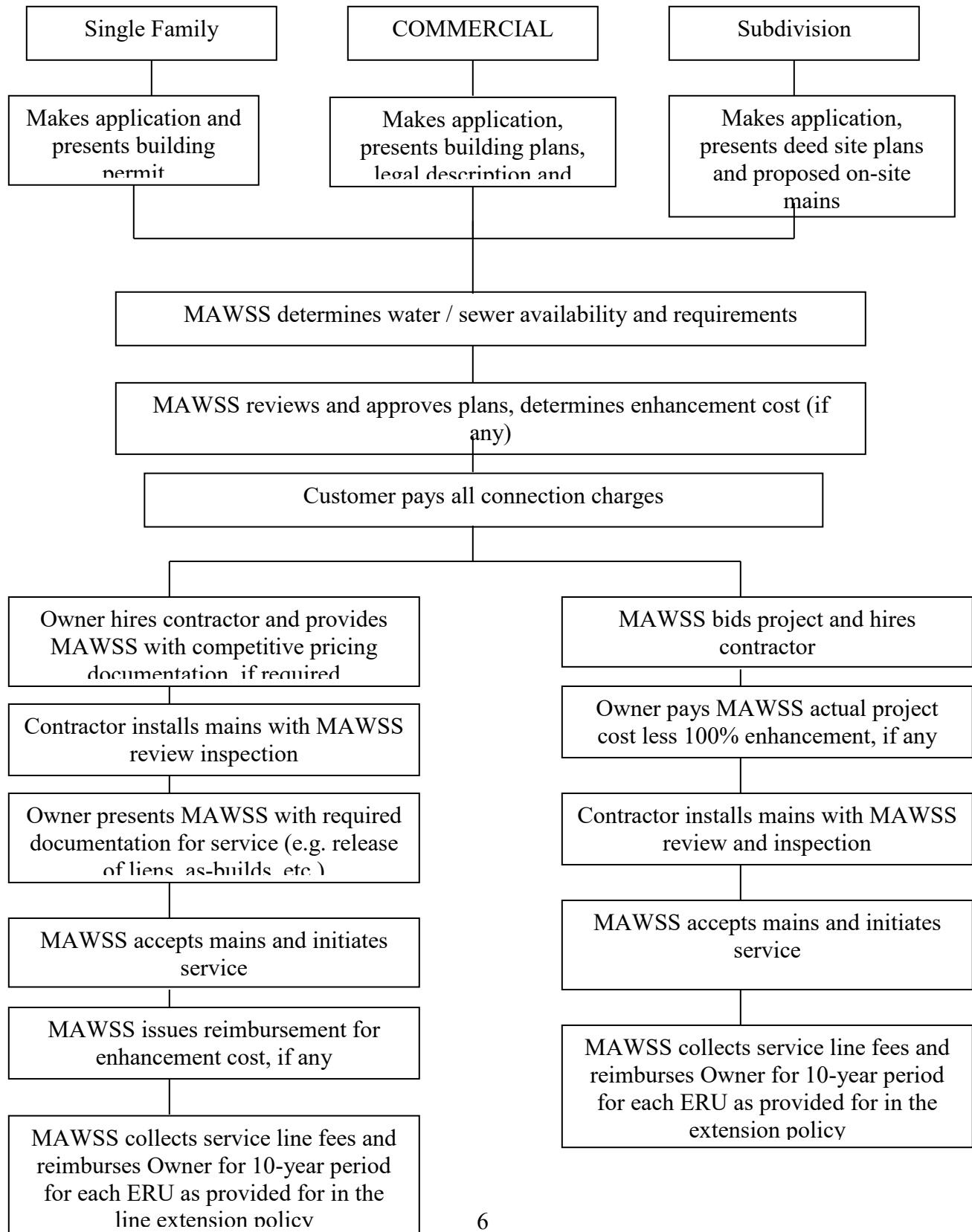

The Owner/Developer shall execute a Restrictive Covenant, recorded in the Public Records, with conditions to meet specific circumstances, as determined by MAWSS, including, at a minimum, that all mains shall be the property of MAWSS, with title vested in MAWSS from the date construction is accepted by MAWSS.

## **7.5 Main Extension Process – Existing Communities**

Residents within existing communities may request MAWSS to install water and/or sewer as follows:

1. Applicants shall provide a map, a definition of the area to be served, demographics, and a survey of potential users to MAWSS.
2. MAWSS shall evaluate the information provided, identify existing facilities, and develop preliminary cost estimates for construction of main extension(s).
3. MAWSS will determine project viability as determined by the number of potential connections and availability of capital funds.
4. MAWSS will report its findings to residents of the community, including cost estimates to ascertain support and willingness to participate. Each resident who wishes to participate will be asked to execute and return to MAWSS a Restrictive Covenant or an owner's acknowledgement of restrictions and obligations.
5. If the money committed by the favorable responders does not cover the cost of the project, MAWSS will contribute the balance if the calculated payback period is 20 years or less. The contribution is contingent on availability of funds in the MAWSS Capital Budget.

SEE NEXT PAGE



**MAIN EXTENSION PROCESS  
EXISTING COMMUNITIES**

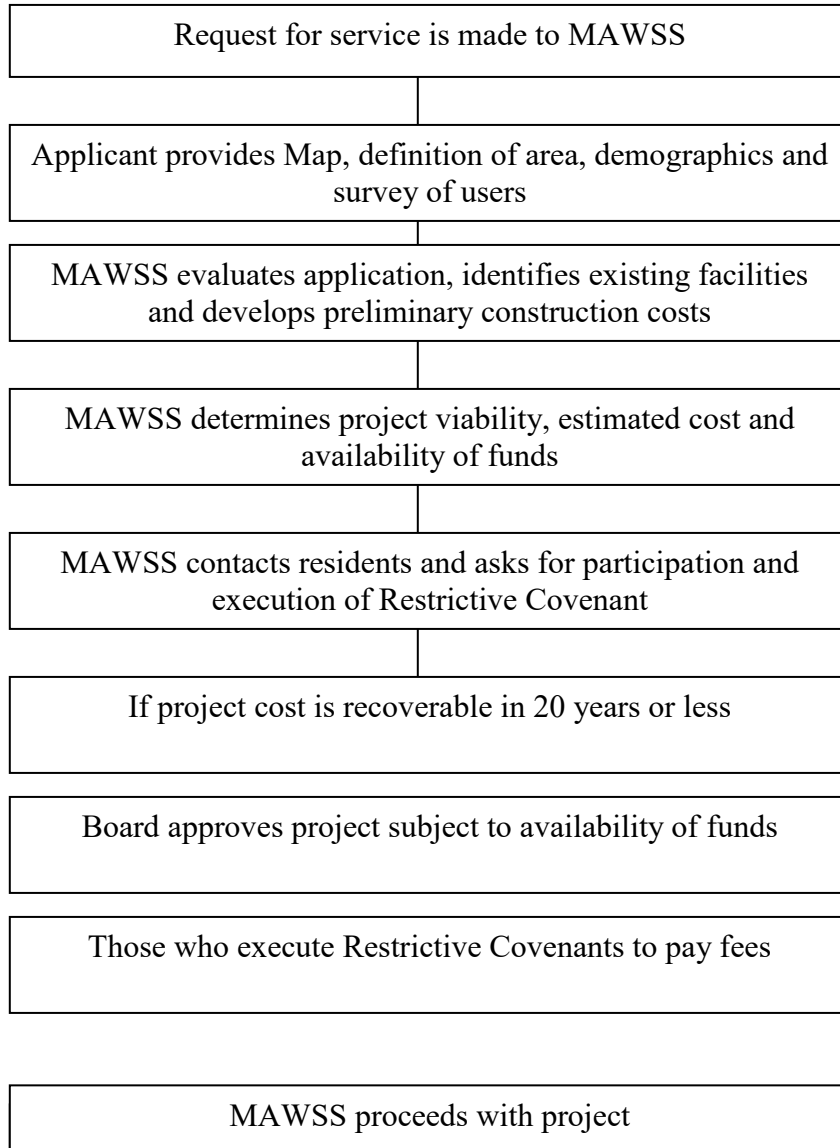

## **7.6 Service to Subdivisions**

Where the subdivision developer has paid for the installation of water/sewer lines within the streets and easements of any subdivision and is not being reimbursed and pays for the connection to water and/or sewer service, the owner shall pay a minimum charge for each connection, as established by MAWSS.

## **7.7 Contribution for New Developments**

For all new residential developments connecting to both water and sewer service from MAWSS, a contribution towards the cost of development will be made by MAWSS. The money may be used toward an extension of MAWSS' existing water and/or sewer lines, or toward the construction of water and sewer lines within the development, when the contribution amount exceeds the cost of the extension. The contribution shall apply to each lot within the initial unit being developed. Future platted units shall be credited with 25% of the contribution amount. When a second unit is constructed, the other 75% will be contributed for the water/sewer lines within that unit.

For all new residential developments connecting to either (not both) water or sewer service from MAWSS, the contribution shall be 66% of the total contribution for both services and shall only be credited against the cost of an extension. If an additional unit is constructed there will be no additional contribution.

Each year, the Board will budget money to be used for contribution payments. The money will be paid as development projects are completed. If the budgeted funds are exhausted prior to the end of the budget year, those projects completed after the funds are exhausted will have first priority to the next budget year's funds.

In addition to the aforementioned contribution, a new development is eligible for reimbursement of its cost for water/sewer line extensions in excess of its normal acreage fee. The developer will receive the acreage fees collected by MAWSS from individual services sold along said extension for a period of ten years after completion of the line extension. The reimbursement does not apply to subdivision developments which connect to said extension by means of another extension.

## **7.8 Fire Protection**

Water service for fire protection purposes is intended to stand ready and to provide a supply of water exclusively for fire protection purposes and no water shall be used from the fire protection system facilities for any other purpose unless the said system is a MAWSS approved fire/domestic dual service, and such dual service is noted in the Contract for Service and all applicable fees paid.

The customer's fire protection apparatus, facilities or system installation (plumbing) to which service is rendered must be entirely separate and apart from the customer's domestic water service unless the system is a MAWSS approved dual system as herein noted. Those existing fire protection facilities and installations which do not conform to this requirement will be reviewed by MAWSS on a case-by-case basis to determine actions required to conform to the aforementioned requirements.

No disconnection of fire protection apparatus, facilities or systems in whole or in part, from water service provided by MAWSS is permissible unless the customer can provide proof of demolition of the existing structure or a letter from the Fire Marshall authorizing the disconnection of the fire protection facilities or system, clearly designating the portion authorized for such disconnection.

No fire line connection will be furnished to anyone using treated water from any service other than MAWSS.

To provide reasonable fire protection to adjacent properties, the installation and location of fire hydrants on any water line having a diameter of 6-inch or more is at the discretion of MAWSS. Upon request by a customer and approval by MAWSS, a fire hydrant may be installed on any water main having a diameter of 6-inch or more. The requesting customer shall pay the cost of installation including material, labor, equipment, and overhead.

When an existing water main is inadequate to provide the fire protection requirements of a new development, the developer will assume all construction costs for the new main required.

No fire hydrant shall be installed on any water main having a diameter less than six inches.

An approved backflow prevention device is required on all fire protection system facilities in accordance with Section 6.0 unless raw water is being used for fire suppression.

Fire lines are to be used only for fire suppression purposes. If a fire line is determined to be used for purposes other than fire suppression, a meter will be installed on the fire line at the customer's expense and future billings will be based on meter size and consumption.

#### **7.9 Service Line Component of the Connection Fee; Reimbursement; Collection; Enhanced Main Extension Rebate**

The payment of or obligation to pay this fee is in advance of service. Residential customers interested in paying for connection fees by the installment method, must sign the required Contract for loans, pay the required minimum down payment of 15% of the total due and remain current on monthly payments of not less than 1/60 of the balance thereafter at MAWSS' current rate of interest compounded monthly on the unpaid balance. In the event of nonpayment, a "Notice of Default" will be sent to the customer prior to discontinuance of service or proceeding against the lien.

Contracts shall only be established in the name of the property holder and will be recorded in Probate Court in order to place a lien on the property in the event of nonpayment. Contracts shall not be allowed for builders and/or contractors in the course of their business or other non-residential customers.

If a contract is in default or has had a bad credit history (rating of less than 92), the contract will not be subordinated by a new mortgage or by refinancing the old mortgage. In these cases, contracts must be paid in full or remain as first lien against the property.

Payment of this fee is in addition to all other installation fees and charges, as established by MAWSS.

When a customer of MAWSS has extended a main that is directly serving, or is available to serve, adjacent property with no existing service, and such property is not owned by said customer, a "Service Line Component of the Connection Fee" shall be collected by MAWSS from the owner at the time service is provided. MAWSS shall reimburse the service line fee collected from those properties provided with a service connection and/or lateral, in accordance with the written agreement between MAWSS and the customer responsible for the main extension, not to exceed actual expenditures less the fee of the original customer's development. MAWSS will collect and refund this fee to the original customer for a period of ten years from the date service is first provided through the main extension.

The Service Line Component of the Connection Fee for water or sewer service will be based on the area of property served. See Section 3.2.

The Fee for any parcel having service, and subsequently subdivided into smaller parcels shall be determined by calculating the fees for each of the newly created parcel sizes, and crediting the larger parcel or largest equal size parcels with the Fee applicable for the beginning parcel size.

The minimum service line component charges for properties adjacent to low-pressure sewer mains shall be at a rate equal to one-half the service line component charges for properties adjacent to gravity sewer mains but no less than established minimum.

It shall be the responsibility of the property owner who is adjacent to a low-pressure sewer main to purchase, install, operate, and maintain a sewage grinder pump station. This station will receive sewage from the property and discharge it into the low-pressure sewer main.

All classes of service that are required to extend a pipe larger than required by their project and larger than 12-inch diameter water pipe and 12-inch diameter sewer (gravity) pipe shall be eligible for an Enhanced Main Extension Rebate for the oversized portion. Project rebate determinations shall be calculated on a project-by-project basis.

#### **7.10 Acceptance of Main Extensions**

MAWSS may at its discretion agree to accept a main extension for ownership, operation, and maintenance subject to the conditions described in this section.

No main extension shall be accepted by MAWSS for ownership, operation, and maintenance, unless the applicant demonstrates that:

1. The main is located in a public right-of-way or within an easement with a minimum width of 20 feet for water or pressure sewer, and 30 feet for gravity sewer.
2. The facility has not been installed under any building or appurtenance thereto.
2. There exists clear access to all easement areas, and there is reasonable assurance that such access will be maintained.
3. All necessary easements have been conveyed to MAWSS by a separate, adequate legal instrument in recordable form.
5. All construction has been performed under the observance and acceptance of MAWSS.

6. The main extension has been constructed and tested in accordance with the requirements of MAWSS' Standard Specifications.
7. All materials and labor meet the current specifications of MAWSS.
8. All necessary permits have been received from MAWSS, county and/or municipality, A.D.E.M. and A.D.O.T.
9. The owner or developer warrants that the main extension has been constructed in accordance with MAWSS' requirements and is free from any and all defects in materials and workmanship.

MAWSS may accept a main extension located within a private right-of-way or within an easement upon appropriate review. Generally, rights-of-way or easements located along rear or side-lots lines are not acceptable to MAWSS.

Prior to acceptance by MAWSS, a written warranty (in a format approved by MAWSS) will be required on all main extensions, wherein the contractor guarantees correction of any defects in the work for a period of two years after MAWSS accepts the main extension. Any developer or contractor who fails to correct any such defect(s) may be required to provide MAWSS a Maintenance Bond or Irrevocable Letter of Credit, up to the amount of 100% of actual construction cost, for any subsequent main extensions.

All main extensions or other facilities to be accepted for ownership, operation, and maintenance by MAWSS shall be conveyed by adequate legal instrument. Prior to conveyances to developer, the owner shall provide MAWSS with:

1. A breakdown of the actual construction cost of said facilities.
2. Copies of paid bills and/or lien waivers, releases, or satisfactions sufficient to indicate that all contractors, subcontractors, and material men have been paid in full. Payment bond and/or a transfer of liens to security may be substituted as deemed appropriate by MAWSS' legal counsel.
3. One set of "as-built" or Record drawings (and video where required) indicating the specific location, depths, and other dimensions of all main facilities and appurtenances as actually constructed and installed.
4. Letter stating all fire hydrants are located satisfactorily, and if required to be moved, relocation will be at the expense of owner.
5. Copy of a satisfactory bacteriological report.

## 7.11 Apartment Complex Meter Conversion

The following procedure governs the process for converting an apartment complex from a master meter to individual meters.

- Step 1:** A written request is received from the owner asking for the conversion of an apartment complex from a master meter to individual meters. The owner must also sign a contract with MAWSS that they will be responsible for any delinquent accounts.
- Step 2:** The apartment complex owner submits record drawings for review by MAWSS staff. If record drawings of the water system within the apartment complex do not exist, they must be prepared before proceeding. The purpose of the staff review will be to advise the owner of the feasibility of the meter conversion before the owner incurs the expense of the design. The cost of the staff review will be billed to the owner. Fees for plan review for apartment complex conversions shall equal 1/2 of residential subdivision per lot charge.
- Step 3:** Following the review of the as-built drawings, additional exploratory work may be specified as follows:
- The locations of exploratory excavations required to verify material types and/or locations. A MAWSS representative must be present during these excavations. Additional excavations may be specified by the engineering firm in Step 6, the design phase.
  - Fire flow testing required, as well as upgrades which will potentially be necessary to correct any inadequate fire flows. Actual upgrades required will be determined in Step 6. Fire flow testing is to be performed by the Board's representatives. Fire flow testing will be billed to the owner. See Fee Schedule for current rate.
  - Locations of additional valving required, if any, will be identified. Additional valve locations may be specified by the engineering firm in Step 6.
  - Upgrades needed to loop the water system, if necessary, will be noted. Additional upgrades may be specified by the engineering firm in Step 6.
- Step 4:** The owner, at his expense, conducts testing as specified in Step 3, and submits the results, in writing, to MAWSS' staff.
- Step 5:** The staff reviews the test report submitted by the owner and recommends to the Board whether the project should proceed to Step 6, the design phase. Should the owner elect to abandon the project, all costs accrued by MAWSS' staff will be paid to the Board by the owner.
- Step 6:** The owner contracts with the Board for design of the meter conversion. The contract, among other things, will specify that:

- The Board will engage an engineering firm to perform the design. The design will conform to the specifications of the Board.
- The owner will pay all costs associated with the design, the bid process, and, with staff oversight and review of, the design and bid process.
- These costs will be paid to the Board monthly by the owner, as they are invoiced by the engineering firm.
- Should the owner cancel the project at any time, he shall be obligated to pay all accrued costs associated with the project.
- The Board must approve of the design prior to advertising for bids.

**Step 7:** Following design, the engineering firm will put the project out to sealed bid. Bids shall be opened at a meeting of the Board.

**Step 8:** The engineering firm and MAWSS' staff will evaluate the bids and make a recommendation to the Board regarding the awarding of the construction contract. The owner will be provided, in writing, the amount of the bid and the name of the successful contractor.

**Step 9:** The owner will advise the Board, in writing, as to whether he elects to proceed with construction or abandon the project. Should he elect to abandon the project, all accrued costs of the project shall be paid by the owner to the Board.

**Step 10:** Should the apartment complex owner elect to proceed with construction, he will contract with the Board for the construction. The contract will, among other things, stipulate that:

- The Board will engage the services of the contractor for the performance of the meter conversion project
- The Board will engage the services of an engineering firm to oversee the construction activities and to prepare record drawings.
- All costs associated with the contractor and the engineering firm shall be paid by the owner, monthly, as they are invoiced to the Board by the contractor and the engineering firm.

**Step 11:** The apartment complex owner will prepare, at his expense, easements for the operation and maintenance of the water system within the apartment complex. The easements shall clearly state that the Board is not responsible for damage to, or replacement of, paving, grass, trees, fences, shrubs, buildings, walls, etc.

**Step 12:** Following construction, the contractor will deliver to the Board record drawings which are accurate and which certify that the construction was performed in accordance with the plans and specifications. The owner will demonstrate through comparison of individual and master meter readings, that the apartment complex water system is free of leaks and unmetered connections. MAWSS personnel will collect the meter readings used in this comparison. The meter reading will be billed to the owner at actual cost. In the event that the master meter and individual meter data indicate the presence of leakage, the apartment complex owner will pay any additional repairs, testing, and engineering fees necessary to locate and correct the leakage.

**Step 13:** The Board accepts the water system for operation and maintenance.

### **7.12 System Design; General Criteria**

Standard Specifications for Water Mains, Sanitary Sewers and Sewage Pumping Stations are developed to establish minimum acceptable standards for the design and construction of water distribution and transmission facilities and wastewater collection and transmission facilities owned, operated, or maintained by MAWSS. Such facilities include water mains, gravity sewers, wastewater force mains, wastewater pump stations, and miscellaneous related appurtenances associated with such systems.

A copy of the Standard Specifications is available for downloading on MAWSS' website at [www.mawss.com](http://www.mawss.com).



## **APPENDIX A**

**No Content**

## **APPENDIX B**

**No Content**

## Appendix C

### Connection Fee Examples (please see Fee Schedule for current rates)

**Example 1A: Fees Associated with Residential Development (Fees Paid by Developer)**

---

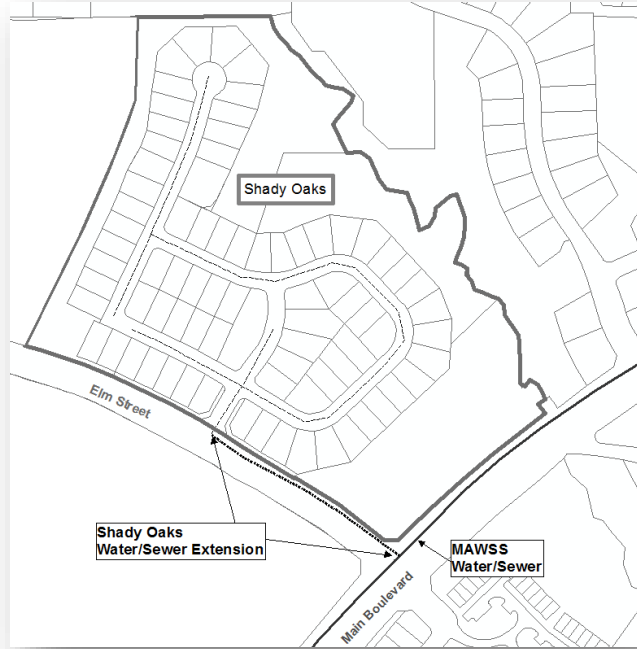

**Scenario:**

A developer purchases property for construction of the Shady Oaks Subdivision. The subdivision will require water and sewer service for single family residences. A wet tap is required to connect the subdivision’s new 6-inch water main to the existing 10-inch MAWSS water main. The platted area of the property is 29.1 acres which is to be subdivided into 78 buildable lots.

**Fees to Be Paid by Developer:**

Fees	Fee Schedule Item Appendix B	Amount
Development Review and Inspection Fee	VI.14.A	\$3,900
Wastewater Capacity Request Application Fee	VI.31.D	\$600
Service Line Component of Connection Fee - Sewer	II.A.2	\$6,000
Water Wet Tap Fee (10"x6")	III	\$1,490
<b>Total Developer Fees</b>		<b>\$11,990</b>

Example 1B: Fees Associated with Residential Development (Fees Paid by Builder)

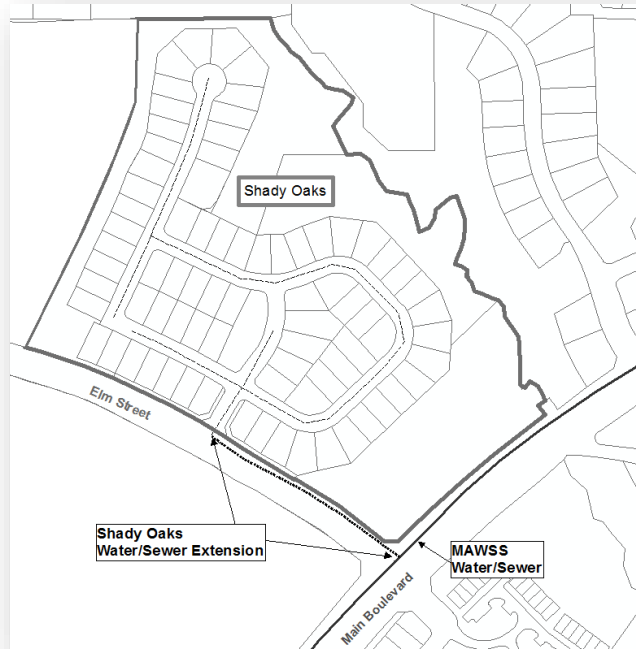

Scenario:

A developer purchases property for construction of the Shady Oaks Subdivision. The subdivision will require water and sewer service for single family residences. A wet tap is required to connect the subdivision’s new 6-inch water main to the existing 10-inch MAWSS water main. The platted area of the property is 29.1 acres which is to be subdivided into 78 buildable lots.

Fees to Be Paid by Builders (per lot):

Fees	Fee Schedule Item Appendix B	Amount
Capacity Component of Connection Fee-Sewer	II.B	\$720
Capacity Component of Connection Fee-Water	II.B	\$280
Intra-Development Service Account Fee-Sewer	II.C	\$100
Intra-Development Service Account Fee-Water	II.C	\$250
Total Builder Fees (per lot)		\$1,350

Example 2: Fees Associated with Residential Property Outside of a Subdivision

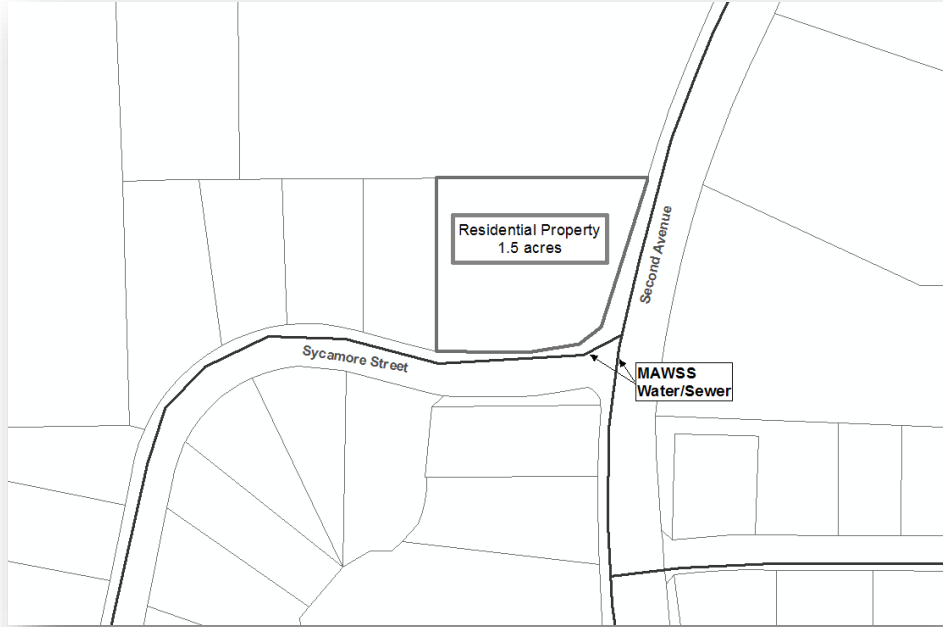

Scenario:

A family purchases a 1.5 acre property outside of an existing subdivision to construct a new home. The property will require water and sewer service and is adjacent to existing MAWSS water and sewer mains. The new home is to be served with a 5/8-inch water meter.

Fees to Be Paid:

Fees	Fee Schedule Item Appendix B	Amount
Wastewater Capacity Request Application Fee	VI.31.B	\$25
Service Line Component of Connection Fee - Water	II.A.1	\$350
Service Line Component of Connection Fee-Sewer	II.A.2	\$4,115
Capacity Component of Connection Fee-Water	II.B	\$280
Capacity Component of Connection Fee-Sewer	II.B	\$720
Total Fees		\$5,490

\* Single-family residential customers may finance the builder capacity fees and the developer main line connection fees for up to five (5) years. The financing interest rate may be found in Item VI.11 of Appendix B: Fee Schedule.

Example 3: Fees Associated with Commercial Developments

(Individually Metered Units)

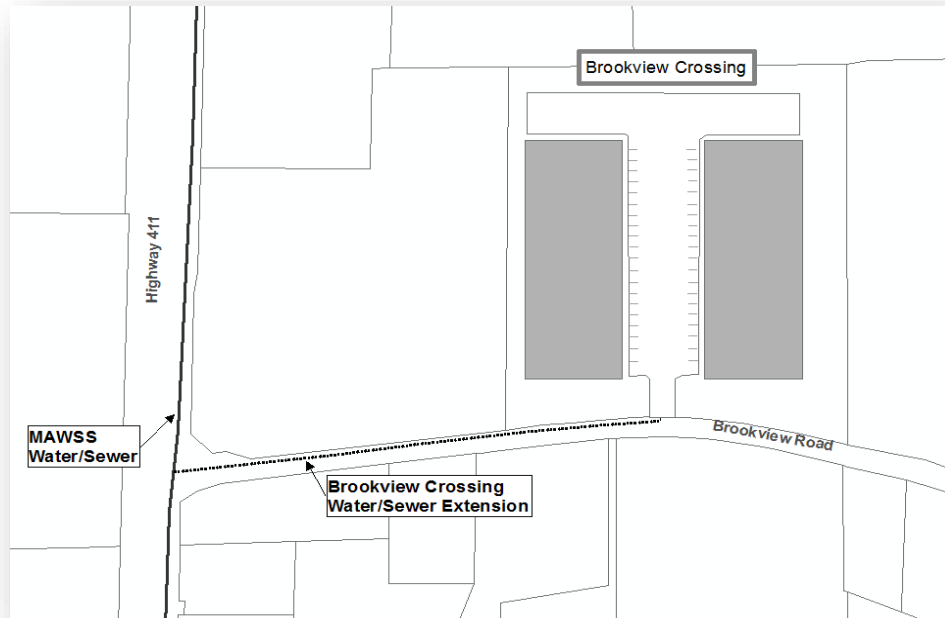

Scenario:

A developer purchases 4.1 acres of property to build the Brookview Crossing shopping complex. The shopping complex will consist of two (2) buildings with 3 rentable units each. A wet tap is required to connect the development’s new 4-inch water main to the existing 10-inch MAWSS water main. Each unit will be served by a water service line with a 5/8-inch meter and a 6-inch sewer lateral.

Fees to Be Paid:

Fees	Fee Schedule Item Appendix B	Amount
Development Review and Inspection Fee	VI.14.B	\$410
Wastewater Capacity Request Application Fee	VI.31.C	\$300
Service Line Component of Connection Fee-Sewer	II.A.2	\$5,645
Capacity Component of Connection Fee-Water	II.B	\$1,680
Capacity Component of Connection Fee-Sewer	II.B	\$4,320
Intra-Development Service Account Fee-Sewer (6 service laterals)	II.C	\$600
Intra-Development Service Account Fee-Water	II.C	\$1,500
Water Wet Tap Fee (10"x4")	III	\$1,080
	Total Fees	\$15,535

\* Contact the Mapping & Connections Department for assistance with other scenarios.

Example 4: Fees Associated with an Industrial Development

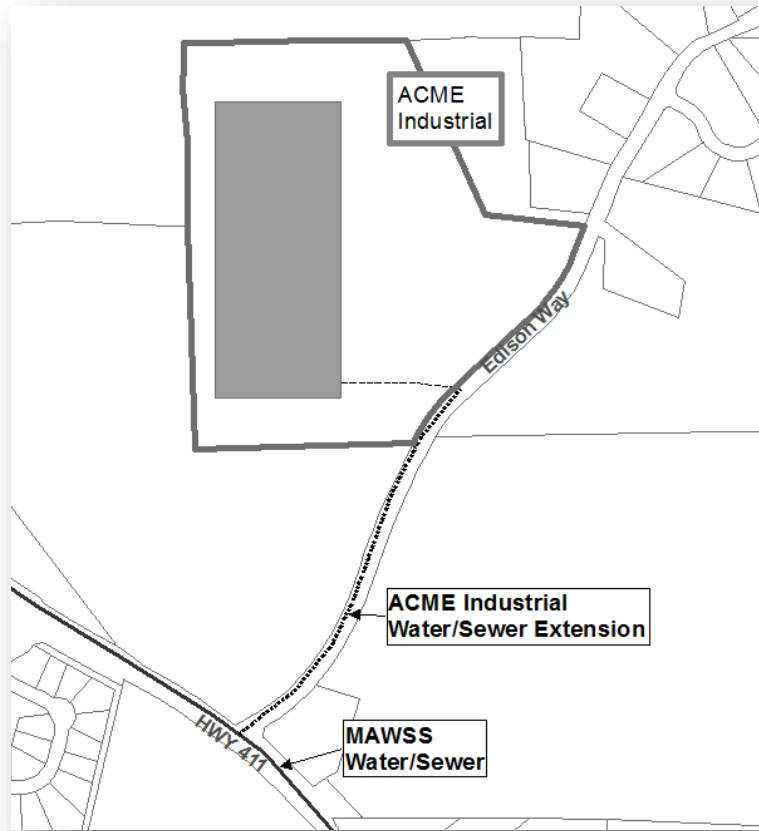

Scenario:

ACME Industrial has purchased 20.3 acres off of Edison Way to build a new facility. A wet tap is required to connect the development's new 6-inch water main to the existing 12-inch MAWSS water main. The new facility will require a 6-inch water meter.

Fees to Be Paid:

Fees	Fee Schedule Item Appendix B	Amount
Development Review and Inspection Fee	VI.14.B	\$2,030
Wastewater Capacity Request Application Fee	VI.31.E	\$1,500
Service Line Component of Connection Fee Water	II.A.1	\$5,000
Service Line Component of Connection Fee- Sewer	II.A.2	\$6,000
Capacity Component of Connection Fee-Water	II.B	\$10,080
Capacity Component of Connection Fee-Sewer	II.B	\$25,920
Water Wet Tap Fee (12"x6")	III	\$1,490
	<b>Total Fees</b>	<b>\$52,020</b>

**MOBILE AREA WATER AND SEWER SYSTEM FEE SCHEDULE  
EFFECTIVE JANUARY 1, 2024**

**I. MONTHLY FEES & CHARGES**

**A. BASIC WATER & SEWER RATE PER 1000 GALS**

(In Gallons) OVER - UP TO	WATER (\$/kgal)	SEWER (\$/kgal)
0 - 2,000,000	\$3.85	\$9.62
2,000,000 - 10,000,000	\$3.43	\$9.62
10,000,000 - Over	\$3.07	\$9.62

**MONTHLY FIXED FEES**

**ADMIN FEE**

Admin fee is \$4.60 for all customers.

**CAPITAL IMPROVEMENT FEE**

**LINE SIZE**

LINE SIZE	WATER	SEWER
5/8" - 3/4"	\$0.12	\$1.88
1"	\$0.41	\$6.02
1 1/2"	\$0.88	\$12.79
2"	\$1.50	\$21.81
3"	\$3.25	\$47.37
4"	\$6.51	\$94.73
6"	\$11.27	\$163.89
8"	\$17.88	\$260.12
10"	\$23.93	\$348.09
12"	\$44.45	\$646.54

**B. MINIMUM CHARGE/METER SIZE AND CONSUMPTION (1,000 GALLONS)**

\*\*\*note minimum charge does not include the monthly fixed fees

LINE SIZE	PER 1,000 GALLONS	WATER (\$/Kgal)	SEWER (\$/Kgal)
5/8" - 3/4"	2.5	\$9.63	\$24.05
1"	8	\$30.80	\$76.96
1 1/2"	17	\$65.45	\$163.54
2"	29	\$111.65	\$278.98
3"	63	\$242.55	\$606.06
4"	126	\$485.10	\$1,212.12
6"	218	\$839.30	\$2,097.16
8"	346	\$1,332.10	\$3,328.52
10"	463	\$1,782.55	\$4,454.06
12"	860	\$3,311.00	\$8,273.20

**C. FIRE SERVICE - STAND-BY CHARGE**

**LINE SIZE**

LINE SIZE	MONTHLY CHARGE
2"	\$18.00
3"	\$18.00
4"	\$18.00
6"	\$27.00
8"	\$37.00
10"	\$47.00
12"	\$57.00
>12"	Based on Cost

**D. UNTREATED INDUSTRIAL WATER RATE**

rate per million gallons

**Rate (\$/ MG)**  
\$280

**E. DECENTRALIZED SYSTEMS**

Sewer charges are calculated at 197% of the above monthly fees and charges.

NOTE: This fee will go into effect 4/1/2024.

**F. WHOLESALE WATER**

Prichard Water and Sewer

**WATER (\$/kgal)**  
\$2.75

**G. WHOLESALE SANITARY SEWER**

**SEWER (\$/kgal)**  
\$6.06

**H. SEWER FLAT RATE**

\*\*\*note minimum charge does not include Monthly Fixed Fees

**Meter Size**

Meter Size	SEWER
5/8" - Tier 1	\$ 29.82
5/8" - Tier 2	\$ 96.20
1"	\$ 137.57
1 1/2"	\$ 851.37
2"	\$ 949.49
3"	\$ 1,852.81
4"	\$ 2,322.27
6"	\$ 2,322.27

\*\* any meter size greater than 6" will be determined on a case by case basis.



**II. SERVICE FEES & CHARGES**

**A. CAPACITY FEE** - Calculated on the basis of an Equivalent Residential Connection (ERC) for dwelling units and meter-based for all other users.

DWELLING UNIT		ERC	WATER		SEWER
Single Family		1.00	\$	280	\$ 720
2 to 4 Dwelling Units (each unit)		0.75	\$	210	\$ 540
Mobile Home/Multi-Family (each apt./condo. Unit)		0.50	\$	140	\$ 360
Hotel/Motel/Guest House/Bed & Brkfst. (each room)		0.25	\$	70	\$ 180

OTHER USERS	METER SIZE	ERC	WATER		SEWER
	5/8"	1.0	\$	280	\$ 720
	3/4"	1.5	\$	420	\$ 1,080
	1"	2.5	\$	700	\$ 1,800
	1.5"	5.0	\$	1,400	\$ 3,600
	2"	8.0	\$	2,240	\$ 5,760
	3"	16.0	\$	4,480	\$ 11,520
	4"	25.0	\$	7,000	\$ 18,000
	6"	50.0	\$	14,000	\$ 36,000
	8"	80.0	\$	22,400	\$ 57,600
	10"	115.0	\$	32,200	\$ 82,800

**B. SERVICE LINE INSTALLATION (TAP) FEES** - Recovers cost for both water and sewer service line components.

	WATER		SEWER
Flat Fee	N/A	\$	3,200
Line Size < 1"	\$ 1,180		N/A
Line Size = 1"	\$ 1,210		N/A
Line Size = 1 1/2" & 2"	\$ 2,440		N/A
Line Size = 3" & 4"	\$ 3,540		N/A
Line Size > 4"	At Cost		N/A

**C. SERVICE LINE CONNECTION FEE (INCLUDES METER)**

PROJECT (CONNECTION) INSTALLED BY MAWSS

METER SIZE	
5/8"	\$ 245
1"	\$ 375
1.5"	\$ 1,280
2"	\$ 1,475
3"	\$ 1,920
4"	AT COST
6"	AT COST
8"	AT COST
10"	AT COST

**III. CUSTOMER DEPOSITS**

**Residential Accounts** \$ 100

**Commercial Accounts - Cash, Indemnity Bond, or Bank Letter of Credit**

Deposits for Commercial Accounts are based on meter size or consumption, whichever is greater.

Consumption is based on two times the estimated average monthly billing. The minimum deposit per size is listed below:

5/8"	\$ 225
1"	\$ 250
1.5"	\$ 325
2"	\$ 750
3"	\$ 1,700
4"	\$ 3,000
6"	\$ 4,500
8"	\$ 7,500
10"	\$ 10,000
12"	\$ 15,500
Larger than 12"	\$ 20,000

**Security Deposit for Special Events Service** \$ 200

Three (3) times the estimated average monthly billing for tampering with meters or any service - minimum of \$150

Governments, Public Schools, Public Universities: No Deposit Required

**IV. ADDITIONAL FEE CHARGES FOR:**

**Other services:**

Double Head Apartment Meter:

5/8" Meter	\$	325
1" Meter	\$	460
1.5" Meter & Larger		Cost

Backflow preventer required; cost not included

**Irrigation:**

5/8" Double Head Irrigation Meter, including backflow	\$	410
1" Double Head Irrigation Meter, including backflow	\$	560
5/8" Meter - New Tap Irrigation	\$	1,590
1" Meter - New Tap Irrigation	\$	1,770
1.5" Meter & Larger		Cost

Backflow preventer required; cost not included

**V. Wet Taps (Tapping Valve & Sleeve)**

4"x2" (Tapping Valve & Sleeve)	\$	1,230
4"x4"	\$	1,690
6"x2"	\$	1,230
6"x4"	\$	1,690
6"x6"	\$	2,320
8"x2"	\$	1,230
8"x4"	\$	1,690
8"x6"	\$	2,320
8"x8"	\$	2,630
10"x2"	\$	1,230
10"x4"	\$	1,690
10"x6"	\$	2,320
10"x8"	\$	2,550
12"x2"	\$	1,230
12"x4"	\$	1,720
12"x6"	\$	2,320
12"x8"	\$	2,550
12"x10"	\$	3,360
16"x2"	\$	1,230
16"x4"	\$	1,720
16"x6"	\$	2,320
16"x8"	\$	2,550
16"x10"	\$	3,360
16"x12"	\$	4,450
20"x2"	\$	1,230
20"x6"	\$	2,320
20"x8"	\$	2,550
24"x6"	\$	2,320
24"x8"	\$	2,550
24"x10"	\$	3,360
24"x12"	\$	4,450
30"x6"	\$	2,320
30"x8"	\$	2,550
30"x10"	\$	3,360
30"x12"	\$	4,450
36"x2"	\$	1,230
36"x6"	\$	2,320
36"x8"	\$	2,550
36"x12"	\$	4,450
Fire Line Connection		Cost

**Additional Sewer Laterals**

6" Sewer Lateral - 0'-8' Depth	\$	3,200
6" Sewer Lateral - 8'-12' Depth	\$	3,600
6" Sewer Lateral - 12' Depth & Deeper		Cost
8" Sewer Lateral & Larger		Cost

**VI. Tapping Fee Charges - Additional Services**

When tap requires work within the City right-of-way, City permit fees will be charged.

Water permit	\$	150
Sewer Permit	\$	250

Additional costs for street cutting will be charged at cost.

**VII. INDUSTRIAL PRETREATMENT PROGRAM FEES AND CHARGES**

	<b>Category 1 Food Service</b>	<b>Category 2 Industrial</b>	<b>Category 3 Industrial</b>
Annual Administrative	\$ -	\$ 260	\$ 260
Compliance Sampling Inspection Fee (per sampling day)	\$ 15	\$ 160	\$ 160
Compliance Evaluation Inspection (annual)		\$ 250	\$ 250
Administrative grease trap/grease management per month*	\$ 30		
Surcharges:	Per lb.	Per lb.	Per lb.
Oil and Grease (>100 mg/l)	\$ 0.29	\$ 0.29	\$ 0.29
Total Suspended Solids (>250 mg/l)		\$ 0.25	\$ 0.25
Biochemical Oxygen Demand (>280 mg/l)		\$ 0.28	\$ 0.28
Ammonia Nitrogen (greater than 20 ppm)		\$ 0.94	\$ 0.94

\*Contact laboratory analysis fees are billed to user on a direct reimbursement basis.

Pretreatment Rules and Regulations stipulate that Industrial Users shall pay a minimum charge of \$1,000 for each violation.

**VIII. MISCELLANEOUS FEES & CHARGES**

1) SERVICE CHARGE	
a) Regular Service, 8:00 a.m. to 5:00 p.m.	\$60
b) Priority Service, nights, weekends and holidays	\$100
c) Go Back/Turn on Charge	\$60
d) Cut for Repairs	\$60
2) METER TEST FEE - 5/8" TO 1 1/2"	\$150
Meter Test Fee - Greater than 1 1/2"	\$400
3) TAMPERING CHARGE	
Initial Occurrence (minimum)	\$500
Repeat Occurrence (minimum)	\$500
4) DELINQUENT ACCOUNT CHARGE	10% of the delinquent amount
5) FOUND ON PENALTY	\$40
6) DELINQUENT PROCESSING FEE	\$5
7) RETURN CHECK CHARGE	\$35
8) BACKDATED SERVICE CHARGE	\$20
9) DORMANT ACCOUNT CHARGE (Annually)	\$10
10) STATE TAX (Water Only)	4%
11) DEVELOPMENT REVIEW and INSPECTION FEE	
a) Subdivision Fee (per lot)	\$50 (\$500 minimum)
b) Commercial Development (per acre)	\$100 (\$500 minimum)
c) Apartments Fee (per unit)	\$10 (\$500 minimum)
12) EASEMENT/RIGHT-OF-WAY VACATION CHARGE (each)	\$75
13) FIRE HYDRANT METER RENTAL CHARGES (must be prepaid)	
Hydrant Meter	
a) Security deposit on rental (refundable)	\$1,500
b) Pick-up service charge	\$100
14) METER RELOCATION CHARGE	
a) Developed Subdivision	\$470
b) All Others	Cost
15) TIPPING FEE (per truck - minimum)	\$20
a) Waste, non-surchageable	Basic sewer rates
16) SEPTIC WASTE (per gallon)	\$0.08
17) GREASE TREATMENT (per gallon)	\$0.10
18) LOCATE SEWER SERVICE CONNECTION	
a) Locate by video	\$1,260
b) Locate by excavation	\$2,520
19) UNPLUGGING SEWER ONLY LATERAL	\$2,500
20) MOBILIZATION and DEMOBILIZATION FEE	
(i.e. disconnecting sewer only customers)	\$325
21) RE-ESTABLISH CUT-OFF SEWER SERVICE (from delinquent status)	\$500
22) CUTTING LATERAL IF ELDER VALVE IN PLACE	\$250
23) RECONNECTING LATERAL IF ELDER VALVE IN PLACE	\$250
24) UNAUTHORIZED STORMWATER/RAINFALL, OTHER DRAINAGE INFLOW INTO SEWAGE SYSTEM CHARGE	
a) Non-rental residential per month	\$30
b) Other properties per month	\$90
25) CAPACITY REQUEST APPLICATION	
a) Private residence in existing reserved subdivision	no charge
b) Private residence not in existing reserved subdivision	\$50
c) Commercial development (per building)	\$300
d) Proposed subdivision, apartments, or condominiums	\$600
e) Industrial development	\$1,500
26) READ DUCT METERS OR FOR EACH ADDITIONAL METER	\$10
27) METER REREAD FEE	\$60
28) UNCOVER/INACCESSIBLE METER CHARGE	
a) Charge to uncover meter due to dirt, debris, blacktop	Cost to MAWSS
b) Charge to remove vehicle off meter box	Towing Fee Plus Cost
c) Fenced meters/gate locked/meter inaccessible	\$50
29) HOT METER	\$500
30) FIRE FLOW TESTING	\$225
31) BACK FLOW PREVENTION	
a) Assembly testing	\$90/Test
b) Assembly repair and re-testing	Cost

*The Board retains the right to charge customers for the cost of providing special services in unique circumstances not anticipated by the above standard fees and charges.*

THIS  
PAGE  
INTENTIONALLY  
BLANK