

**INVITATION FOR BID**  
**August 22, 2025**

INVITATION FOR BID NUMBER	IFB 25-042
NAME OF BID	Annual Contract for Cast Iron Valve Boxes & Risers
BIDS WILL BE RECEIVED AT	MAWSS Bid Box Donaghey Business Entrance 4725 Moffett Road Mobile, AL 36618  If sending bids by UPS/Fed Ex, deliver to the Warehouse: 1610 Shelton Beach Rd. Ext., Mobile, AL 36618
BID OPENING DATE	September 5, 2025
BID CLOSING TIME	10:30 am Central Time
AWARD WILL BE MADE BY	Total Cost & Lead Time
CONTRACT PERIOD	11/1/25 through 10/31/26 with two 1-year extension options
MATERIAL DELIVERED TO	MAWSS Warehouse 1610 Shelton Beach Road Ext Mobile, AL 36618
ADDITIONAL INFORMATION CONTACT	Mike Grimes (251) 402-0042 or <a href="mailto:mgrimes@mawss.com">mgrimes@mawss.com</a>
APPLICABLE SDP POLICY	NONE

Sealed bids must be in the Purchasing Department no later than the time specified in order to be considered. Submissions received after the deadline will not be considered. Envelopes must bear the name of the supplier, company address and the words “IFB 25-042 CI Valve Boxes & Risers” or “IFB 25-042 NO QUOTE.” Facsimile or email bids will not be accepted.

All bids must be submitted on the attached forms or your bid will be disqualified. Bidder shall furnish all the information required by the solicitation. The bidder’s name must be typed or printed on the bid sheet, and signed by the bidder or appropriate authorized executive officer of the bidder’s company. Bidders must initial any changes or erasures. Bidders should retain a copy of bids for their records.

Bidders shall acknowledge receipt of all addenda to this solicitation by signing and returning each addendum or by identifying the addendum number and the date on the bid form. Failure to acknowledge receipt of any addendum by a bidder will result in rejection of the bid if MAWSS determines that the addendum contains information that materially changes the requirements.

All bids shall be quoted FOB Destination, freight prepaid with no additional charges. Unless otherwise specified in the bid, all prices will be on a firm-fixed price basis and are not subject to adjustments based on costs incurred. MAWSS reserves the right to reject any or all bids submitted, to waive any informality in any bid or in the bid process, or to terminate the bid process at any time, if deemed by MAWSS to be in MAWSS’s best interest.

A Purchase Order and this “Invitation for Bid” with “Specifications,” “Conditions,” “Bid Form,” signed by the successful bidder’s authorized representative, and all attached drawings and other documents furnished by MAWSS to the bidders with the Invitation for Bid in order to illustrate the contract requirements, will constitute a contract for the goods and/or services to be purchased.

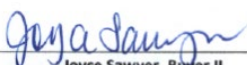
  
Joyce Sawyer, Buyer II  
Board of Water and Sewer Commissioners

## **IFB 25-042 Cast Iron Valve Boxes & Risers CONDITIONS**

The Board of Water and Sewer Commissioners of the City of Mobile will accept bids for **Cast Iron Valve Boxes & Risers** in our Purchasing Department Bid Box located in the Business Entrance at 4725 Moffett Road, Mobile, AL 36618 **no later than 10:30 a.m.** local time on **September 5, 2025**. Bids will be opened immediately after bid closing time in the Operations Center Board Room located at the Customer Service entrance. Award will be by **Total Cost & Lead Time**. The bidder offers and agrees, if this bid is accepted, to furnish the items as defined in the specifications for the unit price set opposite each item. Pricing shall be FOB Mobile, Alabama. All items shall be delivered to our **Warehouse** located at **1610 Shelton Beach Rd Ext.** or to the job site as needed. The bidder shall state the expected length of delivery time on the Bid Form.

Bidder understands and agrees that manufacturer and part numbers are provided for descriptive purposes only. Items of equal or better quality will be considered but must be approved by MAWSS in writing. Upon delivery, if the quality, durability or performance of any product represented as equal or better is determined by MAWSS to be unsatisfactory, MAWSS will require a suitable substitute or will require that the originally specified item be delivered, at the unit price originally offered by bidder. No substitution for items to be provided pursuant to this contract shall be permitted during the contract period without the express written consent of MAWSS. All items provided shall be for commercial use and for the purposes reflected in the contract documents.

No bid on closed out or discontinued item(s) will be accepted. Item(s) that have a determinable shelf life must be disclosed at the time of bid submittal.

Bidder understands that his/her bid shall be good and may not be withdrawn for a period of sixty (60) calendar days after the scheduled closing time for receiving bids.

Bidder understands and agrees that quantities will be purchased by MAWSS on an "as needed" basis to replenish inventory. MAWSS shall not be committed to the purchase of a pre-established minimum quantity for any one item.

A bidder may not modify its bid after bid opening. Errors in the extension of unit prices stated in a bid or in multiplication, division, addition or subtraction in a bid may be corrected by the MAWSS Purchasing Buyer prior to award. In such cases, unit prices shall not be changed.

It is the responsibility of the bidder to determine prior to the bid opening whether any amendment, additions, deletions or changes of any type have been made to this Invitation for Bid, Conditions, Specifications, Bid Form or any of the other bid documents. Bid documents and any amendments made to this bid will be posted on our website at [www.mawss.com](http://www.mawss.com).

Invoicing Requirements: Invoices need to be emailed to Accounts Payable at [AcctsPayable@mawss.com](mailto:AcctsPayable@mawss.com). Please include purchase order number on all invoices.

**END OF CONDITIONS**

**IFB 25-042 Cast Iron Valve Boxes & Risers  
SPECIFICATIONS**

**Category A**

<u>Lawson #</u>	<u>Valve Boxes and Valve Box Risers</u>	<u>Minimum SOH Qty</u>	<u>12 mth usage</u>
1) 12300374	Cast Iron Valve Box Complete (3 Pieces) Size 18 – 24”	50	72
2) 12300375	Cast Iron Valve Box Complete (3 Pieces) Size 24” – 36”	50	79
3) 12300360	Cast Iron Valve Box Lid (“Water” Imprinted on Lid)	25	110
4) 12300365	Cast Iron Valve Box Lid (“Sewer” Imprinted on Lid)	10	14
5) 12300390	1” Tall, Cast Iron Valve Box Riser	50	149
6) 12300400	1-1/2” Tall, Cast Iron Valve Box Riser	50	119
7) 12300410	2” Tall, Cast Iron Valve Box Riser	50	77
8) 12300420	4” Tall, Cast Iron Valve Box Riser	25	63

**DELIVERY STIPULATIONS:**

- 1) All items with minimum stock on hand quantities listed must be maintained with sufficient stock to allow the vendor to execute delivery of the listed minimum stock on hand quantities to MAWSS within 48 hours upon receipt of purchase order.
- 2) The balance of the quantity listed on the purchase order, minus the stock on hand quantity, will be delivered to MAWSS within 10 working days beginning on the day the purchase order is received.
- 3) By the end of the 10 working days, the vendor must have replaced their stock to maintain the required minimum stock on hand quantity.

**NOTE:** Award will be made by All or None. There are no guaranteed quantities of **Cast Iron Valve Boxes & Risers** that will be purchased for this contract. Purchases will be made on an as needed basis. Purchase Order numbers are required for all purchases. All deliveries are to be made FOB Destination, Freight Allowed. No additional charges above the bid pricing will be allowed. This includes but is not limited to Fuel Surcharges.

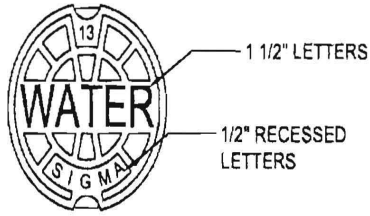

COVER FACE

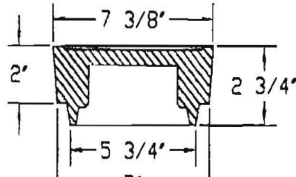

**VB-2600WX**  
COVER SECTION

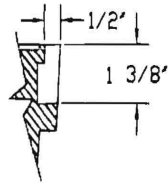

DETAIL  
OF  
PICK HOLE

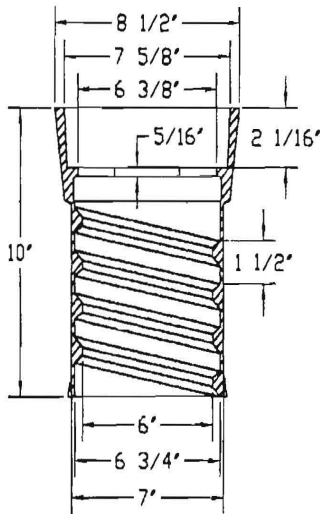

**VB-2611X**  
TOP SECTION

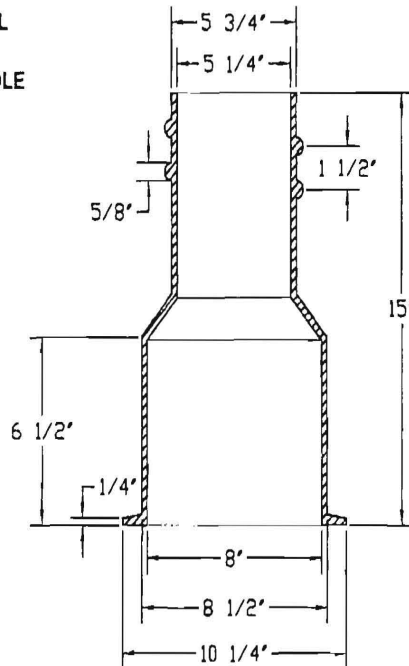

**VB-2612X**  
BOTTOM SECTION



**SIGMA**  
CORPORATION

(800) 824-4513  
PO Box 519  
Alexander City, AL 35011

(877) 857-7909  
691 West Landstreet Road  
Orlando, FL 32824

DRAWN BY: RJL DATE: 12/27/2006

VALVE BOX  
SCREW TYPE

LOAD RATING:  
Meets H20 Loading Standards  
HEAVY DUTY

MATERIAL SPECIFICATION:  
CAST IRON  
ASTM A 48 CLASS 30B

OPEN AREA - SQ. IN.  
N/A

ESTIMATED WEIGHT - LB.  
56

CATALOG NUMBER

**VB-261X**

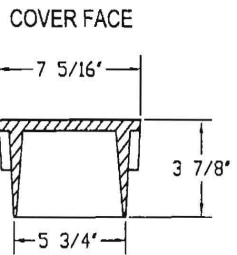
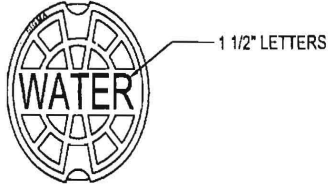

**VB-2600**  
COVER SECTION

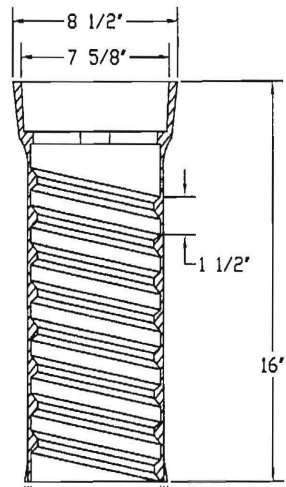

**VB-2621**  
TOP SECTION

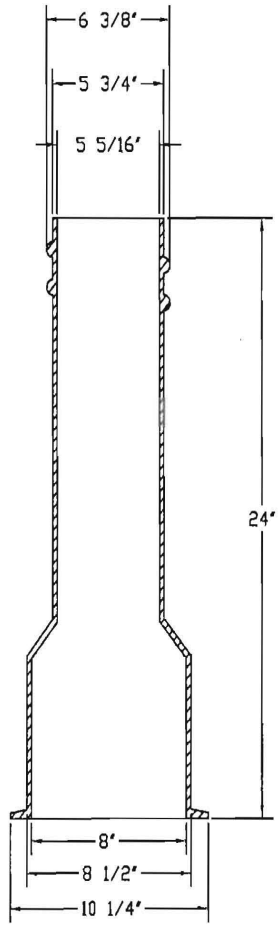

**VB-2622**  
BOTTOM SECTION

  
**SIGMA CORPORATION**  
 (800) 824-4513  
 PO Box 519  
 Alexander City, AL 35011  
 (800) 738-2958  
 PO Box 1043  
 Rockingham, NC 28380

DRAWN BY: R.J.L. DATE: 6/29/2006

**VALVE BOX  
SCREW TYPE**

LOAD RATING:  
Meets H20 Loading Standards  
HEAVY DUTY

MATERIAL SPECIFICATION:  
CAST IRON  
ASTM A 48 CLASS 30B

OPEN AREA - SQ. IN.  
N/A

CATALOG NUMBER  
**VB-262**



**6850 SERIES  
CAST IRON TWO-PIECE VALVE BOXES**  
for 4" through 12" valves, 5<sup>1</sup>/<sub>4</sub>" shaft, screw-type

**SEPARATE UPCODES for VALVE BOX TOPS ONLY (Less Lids)**

Box	TOP Length	**(D-HD) UPCode		**(ND-HD) UPCode		**(ND-Std.) UPCode	
		670610	Wt	670610	Wt	670610	Wt
461-S	(10T)	144939	22	502142	22	112402	15
462-S	(10T)	144939	22	502142	22	112402	15
562-S	(16T)	144946	36	502159	36	112419	22
563-S	(16T)	144946	36	502159	36	112419	22
564-S	(16T)	144946	36	502159	36	112419	22
662-S	(26T)	144953	51	502166	51	112426	38
664-S	(26T)	144953	51	502166	51	112426	38
666-S	(26T)	144953	51	502166	51	112426	38
668-S	(26T)	144953	51	502166	51	112426	38

\*\*NOTE: D=Domestic ND=Non-Domestic HD=Heavy Duty Weight Std.=Standard Weight

**EXTENSIONS**

Item/Description	Height Increase	**(D-HD) UPCode		**(ND-Std.) UPCode	
		670610	Wt	670610	Wt
#58 Screw-Type	14	145141	29	---	---
#59 Screw-Type	18	145158	30	---	---
#60 Screw-Type	24	145059	37	112389	29

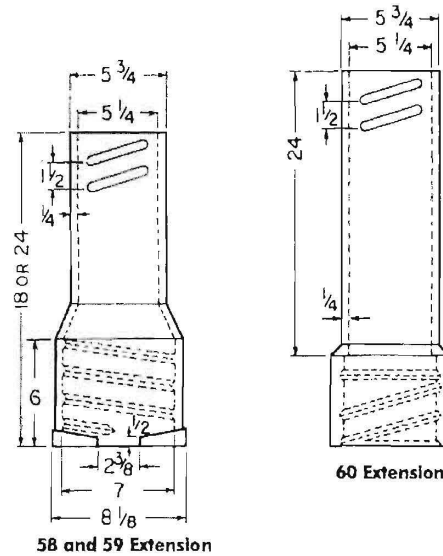

**SEPARATE UPCODES for VALVE BOX BOTTOMS ONLY**

Box	Bottom Length	**(D-HD)UPCCode		**(ND-HD)UPCCode		**(ND-Std.)UPCCode	
		670610	Wt	670610	Wt	670610	Wt
461-S	(15B)	145004	27	502173	27	112242	20
462-S	(24B)	145011	35	502180	35	112259	28
562-S	(24B)	145011	35	502180	35	112259	28
563-S	(30B)	144991	42	502197	42	112266	38
564-S	(36B)	145028	49	502203	49	112273	44
662-S	(30B)	144991	42	502197	42	112266	38
664-S	(36B)	145028	49	502203	49	112273	44
666-S	(24B)	145011	35	502180	35	112259	28
668-S	(36B)	145028	49	502203	49	112273	44
	(48B)	---	---	---	---	452737	62
	(60B)	---	---	---	---	452744	85

\*\*Note: D=Domestic ND=Non-Domestic HD=Heavy Duty Weight Std.=Standard Weight

**END OF SPECIFICATIONS**

**IFB 25-042 Cast Iron Valve Boxes & Risers**  
**BID FORM**

**Category A**

	<u>Lawson #</u>	<u>Description</u>	<u>Usage 12 month</u>	<u>Unit Price</u>
1)	12300374	CI Valve Box Complete Size 18" – 24"	72	\$_____ each
2)	12300375	CI Valve Box Complete Size 24" – 36"	79	\$_____ each
3)	12300360	CI Valve Box Lid "Water"	110	\$_____ each
4)	12300365	CI Valve Box Lid "Sewer"	14	\$_____ each
5)	12300390	CI Valve Box Riser	149	\$_____ each
6)	12300400	1-1/2" CI Valve Box Riser	119	\$_____ each
7)	12300410	2" CI Valve Box Riser	77	\$_____ each
8)	12300420	4" CI Valve Box Riser	63	\$_____ each

Manufacturer \_\_\_\_\_ Model \_\_\_\_\_

Delivery ARO \_\_\_\_\_ Payment Terms \_\_\_\_\_

Company Name \_\_\_\_\_

Address \_\_\_\_\_ City, State, Zip \_\_\_\_\_

Submitted By \_\_\_\_\_ Title \_\_\_\_\_  
Please Print

Phone \_\_\_\_\_ Email Address \_\_\_\_\_  
Please Print

The signer declares under penalty of perjury that she/he is authorized to sign this document and bind the company or organization to all of the terms and conditions of this agreement.

Signature \_\_\_\_\_ Date \_\_\_\_\_